

CITIZEN

Thermal Transfer Barcode & Label Printer

**CL-S700 III/CL-S703 III/
CL-S700 III R/CL-S703 III R**

User's Manual

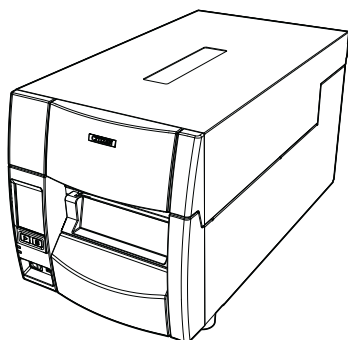

CL-S700 III
CL-S703 III

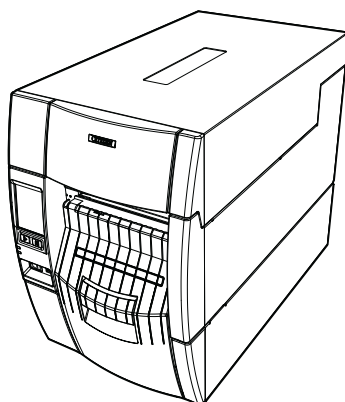

CL-S700 III R
CL-S703 III R

CITIZEN SYSTEMS JAPAN CO., LTD.

WEEE MARK

En

If you want to dispose of this product, do not mix it with general household waste.

There is a separate collection systems for used electronics products in accordance with legislation under the WEEE Directive and is effective only within European Union.

Ge

Wenn Sie dieses Produkt entsorgen wollen, dann tun Sie dies bitte nicht zusammen mit dem Haushaltsmüll. Es gibt im Rahmen der WEEE-Direktive innerhalb der Europäischen Union gesetzliche Bestimmungen für separate Sammelsysteme für gebrauchte elektronische Geräte und Produkte.

Fr

Si vous souhaitez vous débarrasser de cet appareil, ne le mettez pas à la poubelle avec vos ordures ménagères. Il existe un système de récupération distinct pour les vieux appareils électroniques conformément à la législation WEEE sur le recyclage des déchets des équipements électriques et électroniques qui est uniquement valable dans les pays de l'Union européenne.

Les appareils et les machines électriques et électroniques contiennent souvent des matières dangereuses pour l'homme et l'environnement si vous les utilisez et vous vous en débarrassez de façon inappropriée.

Sp

Si desea deshacerse de este producto, no lo mezcle con residuos domésticos de carácter general. Existe un sistema de recogida selectiva de aparatos electrónicos usados, según establece la legislación prevista por la sobre residuos de aparatos eléctricos y electrónicos (RAEE), vigente únicamente en la Unión Europea.

It

Se desiderate gettare via questo prodotto, non mescolatelo ai rifiuti generici di casa. Esiste un sistema di raccolta separato per i prodotti elettronici usati in conformità alla legislazione RAEE, valida solo all'interno dell'Unione Europea.

Du

Deponer dit product niet bij het gewone huishoudelijk afval wanneer u het wilt verwijderen. Er bestaat ingevolge de WEEE-richtlijn een speciaal wettelijk voorgeschreven verzamelstelsel voor gebruikte elektronische producten, welk alleen geldt binnen de Europese Unie.

Da

Hvis du vil skille dig af med dette produkt, må du ikke smide det ud sammen med dit almindelige husholdningsaffald. Der findes et separat indsamlingsystem for udtjente elektroniske produkter i overensstemmelse med lovgivningen under WEEE-direktivet, som kun er gældende i den Europæiske Union.

Por

Se quiser deitar fora este produto, não o misture com o lixo comum. De acordo com a legislação que decorre da Directiva REEE – Resíduos de Equipamentos Eléctricos e Electrónicos, existe um sistema de recolha separado para os equipamentos electrónicos fora de uso, em vigor apenas na União Europeia.

Pol

Jeżeli zamierzasz pozbyć się tego produktu, nie wyrzucaj go razem ze zwykłymi domowymi odpadkami. Według dyrektywy WEEE obowiązującej w Unii Europejskiej dla używanych produktów elektronicznych należy stosować oddzielne sposoby utylizacji.



COMPLIANCE STATEMENT FOR EUROPEAN USERS

CE marking shows conformity to the following criteria and provisions:
Low Voltage Directive (2014/35/EU), EMC Directive (2014/30/EU), and
RoHS directive (2011/65/EU)

Full text of the EU declaration of conformity is available at the following
internet

address:

http://www.citizen-systems.co.jp/en/printer/download/eu_doc.html

FCC COMPLIANCE STATEMENT FOR AMERICAN USERS

This equipment has been tested and found to comply with the limits for a Class A digital device, pursuant to Part 15 of the FCC Rules. These limits are designed to provide reasonable protection against harmful interference when the equipment is operated in a commercial environment.

This equipment generates, uses, and can radiate radio frequency energy and, if not installed and used in accordance with the instruction manual, may cause harmful interference to radio communications.

Operation of this equipment in a residential area is likely to cause harmful interference in which case the user will be required to correct the interference at his own expense.

EMI COMPLIANCE STATEMENT FOR CANADIAN USERS

This Class A digital apparatus complies with Canadian ICES-003.

This equipment generates and uses radio frequency energy and if not installed and used properly, that is, in strict accordance with the manufacturer's instructions, may cause interference to radio and television reception. This digital apparatus does not exceed the Class A limits for radio noise emissions from digital apparatus set out in the Radio Interference Regulations of the Canadian Department of Communications. This equipment is designed to provide reasonable protection against such interference in a residential installation. However, there is no guarantee that interference will not occur in a particular installation. If this equipment does cause interference to radio or television reception, which can be determined by turning the equipment off and on, the user is encouraged to try to correct the interference by one or more of the following measures:

- Reorient or relocate the receiving antenna.
- Increase the separation between the equipment and receiver.
- Connect the equipment into an outlet on a circuit different from that to which the receiver is connected.
- Consult the dealer or an experienced radio/TV technician for help.

CAUTION:

Use shielded cables to connect this device to computers.

Any changes or modifications not expressly approved by the grantee of this device could void the user's authority to operate the equipment.

ETAT DE CONFORMITE EMI A L'USAGE DES UTILISATEURS CANADIENS

Cet appareil numérique de la classe A est conforme à la norme NMB-003 du Canada.

Cet équipement produit et utilise l'énergie à radiofréquences et s'il n'est pas installé et utilisé correctement, c'est à dire en accord strict avec les instructions du fabricant, il risque de provoquer des interférences avec la réception de la radio et de la télévision.

Le présent appareil numérique n'émet pas de bruits radio électriques dépassant les limites applicables aux appareils numériques de la classe A prescrites dans le Règlement sur le brouillage radioélectrique édicté par le ministère des Communications du Canada.

Cet équipement est conçu pour fournir une protection satisfaisante contre de telles interférences dans une installation résidentielle. Cependant, il n'y a pas de garantie contre les interférences avec les réceptions radio ou télévision, provoquées par la mise en et hors circuit de l'équipement; aussi, il est demandé à l'utilisateur d'essayer de corriger l'interférence par l'une ou plus des mesures suivantes:

- Réorienter l'antenne de réception.
- Installer l'ordinateur autre part, par égard pour le récepteur.
- Brancher l'ordinateur dans une prise de courant différente de façon à ce que l'ordinateur et le récepteur soient branchés sur des circuits différents.

IMPORTANT SAFETY INSTRUCTIONS

- Read all of these instructions and save them for later reference.
- Follow all warnings and instructions marked on the product.
- Unplug this product from the wall outlet before cleaning. Do not use liquid or aerosol cleaners. Use a damp cloth for cleaning.
- Do not use this product near water.
- Do not place this product on an unstable cart, stand or table. The product may fall, causing serious damage to the product.
- Slots and openings on the cabinet and the back or bottom are provided for ventilation.

To ensure reliable operation of the product and to protect it from overheating, do not block or cover these openings. The openings should never be blocked by placing the product on a bed, sofa, rug or other similar surface. This product should never be placed near or over a radiator or heat register. This product should not be placed in a built-in installation unless proper ventilation is provided.

- This product should be operated from the type of power source indicated on the marking label.

If you are not sure of the type of power available, consult your dealer or local power company.

- This product is equipped with a three-pronged plug, a plug having a third (grounding) pin. This plug will only fit into a grounding-type power outlet. This is a safety feature. If you are unable to insert the plug into the outlet, contact your electrician to replace your obsolete outlet. Do not defeat the safety purpose of the grounding-type plug.
- Do not allow anything to rest on the power cord. Do not locate this product where the cord will be walked on.
- If an extension cord is used with this product, make sure that the total of the ampere ratings on the products plugged into the extension cord do not exceed the extension cord ampere rating. Also, make sure that the total of all products plugged into the wall outlet does not exceed 15 amperes for 120V outlet and 7.5 amperes for 220V-240V outlet.
- Never push objects of any kind into this product through cabinet slots as they may touch dangerous voltage points or short out parts that could result in a risk of fire or electric shock. Never spill liquid of any kind on the product.
- Except as explained elsewhere in this manual, don't attempt to service this product yourself. Opening and removing those covers that

are marked "Do Not Remove" may expose you to dangerous voltage points or other risks. Refer all servicing on those compartments to service personnel.

- The mains plug on this equipment must be used to disconnect mains power. Please ensure that the socket outlet is installed near the equipment and shall be easily accessible.
- Unplug this product from the wall outlet and refer servicing to qualified service personnel under the following conditions:
 - A. When the power cord or plug is damaged or frayed.
 - B. If liquid has been spilled into the product.
 - C. If the product has been exposed to rain or water.
 - D. If the product does not operate normally when the operating instructions are followed. Adjust only those controls that are covered by the operating instructions since improper adjustment of other controls may result in damage and will often require extensive work by a qualified technician to restore the product to normal operation.
 - E. If the product has been dropped or the cabinet has been damaged.
 - F. If the product exhibits a distinct change in performance, indicating a need for service.

NOTICE

- Before use, be sure to read this manual. And keep it handy for reference when needed.
- The contents of this manual may change without prior notice.
- Reproduction, transfer, or transmission of the contents of this manual without prior consent is strictly prohibited.
- We are not liable for any damage resulting from the use of the information contained herein, regardless of errors, omissions, or misprints.
- We are not liable for any problems resulting from the use of optional products and consumable supplies other than the designated products contained herein.
- Do not handle, disassemble or repair the parts other than those specified in this manual.
- We are not liable for any damage caused by user's erroneous use of the printer and inadequate environment.
- Data residing in the printer is temporary. Therefore, all data will be lost if power is lost. We are not liable for any damage or loss of profits caused by data loss due to failures, repairs, inspections, etc.
- Please contact us if there are any mistakes or ambiguities within this manual.
- If there are missing or incorrectly collated pages in this manual, contact us to obtain a new manual.

Visit the following site to get documentation, drivers, utilities, and other information.

<https://www.citizen-systems.co.jp/en/printer>

- CITIZEN is a registered trademark of Citizen Watch Co., Ltd.
- Datamax®, I-Class™, and Prodigy Plus® are registered trademarks or trademarks of Datamax-O'Neil Corporation in the U.S.
- Zebra®, Eltron®, ZPL2™, and EPL2™ are registered trademarks of ZIH Corp., USA
- Ethernet is a registered trademark of Fuji Xerox Corporation.
- Maxi Code is a registered trademark of United Parcel Service, Inc. in the U.S.
- QR Code is a registered trademark of DENSO WAVE Incorporated.
- PDF417 is a trademark or registered trademark of Motorola, Inc. in the U.S. and other countries.
- TrueType™ is a trademark of Apple Inc.
- UFST™, CG Triumvirate™, and CG Triumvirate Condensed Bold™ are trademarks of Monotype Imaging, Inc.
- BarTender is a registered trademark of SEAGULL SCIENTIFIC, INC.
- In this product, "Noto Sans Display Medium," "Noto Sans Display Regular," "Noto Sans Display SemiCondensed Regular," "Notosans CJK JP Medium," "Notosans CJK JP Regular," "CS Sans CJK JP," "CS Sans CJK SC," and "CS Sans CJK KR" (https://scripts.sil.org/cms/scripts/page.php?item_id=OFL_web) are used.
- In this product, "Fugue" by Kyoto Software Research, Inc. is included as the file system function.



This product uses Fugue file system from Kyoto Software Research Inc.

- All other trademarks are the property of their respective owners.
- Citizen Systems use these trademarks in accordance with the license of relevant owners.

Copyright© CITIZEN SYSTEMS JAPAN CO., LTD. 2023

License Notice

This product incorporates open source software (hereinafter referred to as OSS) that we use under license agreement with the copyright holders in addition to software for which CITIZEN SYSTEMS hold the rights. We are obligated to inform you about copyright notices, license terms, and other information in accordance with the terms of these licenses.

1. The source code of each OSS incorporated into this product that is applicable to either GNU General Public License or GNU Lesser General Public License is made available in accordance with the licensing terms of the respective license. If you wish to copy, modify, or distribute the applicable OSS, download the source code from the following URL.

<https://www.citizen-systems.co.jp/en/printer/download/oss/ci-s70xiii/download/>

The applicable OSS is provided “as is” without warranty of any kind from us. Furthermore, the period of source code availability is until three years after the end of sales of this product. Please note that we are unable to answer any questions about the source code.

2. A list of the OSS incorporated into this product and the full text of each corresponding license can be viewed from the following URL.

<https://www.citizen-systems.co.jp/en/printer/download/oss/ci-s70xiii/license/>

SAFETY PRECAUTIONS...WHICH SHOULD BE STRICTLY OBSERVED

- To prevent personal injury or property damage, the following shall be strictly observed.
- The degree of possible injury and damage due to incorrect use or improper following instructions is described below.

Warning

Indicates a situation which, if not observed and handled properly, could result in death or serious injury.

Caution

Indicates a situation which, if not observed and handled properly, could result in injury.

Caution

The parts near the mark become hot.
Do not touch them during or immediately after operation.
Doing so may result in burns.

Warning

There is a cutter at the paper ejection port.
Do not put your fingers in this area, as touching it may cause injury.



: This is a mark to call attention to the reader.

Warnings

Warning

- Never perform the following. If not avoided, these may cause damage or trouble to the printer or cause the printer to overheat and release smoke and cause burns or an electrical shock. If the printer is damaged or is malfunctioning, be sure to turn the printer off immediately and remove the power cord from the outlet, then consult our service personnel.
 - Do not place the printer in a poorly ventilated area, or shut off the air vent of the printer.
 - Do not place the printer where chemical reactions occur, such as in laboratories or where air is mixed with salt or gas.
 - Do not use a power voltage or frequency other than those specified.
 - Do not plug/unplug the power cord or attach/detach the interface cable by simply grabbing the power cord or interface cable. Do not pull or carry the printer when the tension of the power cord or interface cable is increased.
 - Do not drop or put foreign matter such as clips and pins into the printer. This may cause problems.
 - Do not plug the power cord into an outlet with many loads.
 - Do not spill drinks such as tea, coffee and juice on the printer or spray insecticide on the printer.

If drink or water is spilled, first be sure to turn the power off and remove the power cord from the outlet, then consult our service personnel.
 - Do not disassemble or modify the printer.
- Discard or safely store the plastic packing bag. This bag should be kept away from children. If the bag is pulled over a child's head, it may cause suffocation.

General Precautions



Caution

Observe these precautions to ensure proper use of the device. Make sure to read these precautions.

- Do not touch the area around the thermal head during or right after the printing process. This area will be hot and may cause burns.
- Prior to operation, read the safety instructions carefully and observe them.
- Do not drop or put foreign matter such as clips and pins into the printer. This may cause problems.
- Be careful when moving or carrying the printer. Dropping the printer may cause injury or property damage.
- Make sure if you open the top cover, it is opened all the way. If only partially open, the cover could slam shut, possibly causing injury.
- When the cover is open, be careful of the corners of the cover. They could cause injury.
- Do not open the printer during printing.
- When cleaning the surface of the printer case, do not use the cloth that is soaked in thinner, trichloroethylene, benzene, ketone or similar chemicals.
- Do not use the printer where there is a lot of oil, iron particles, or dust.
- Do not spill liquids or spray insecticide on the printer.
- Do not jolt or impact to the printer by stepping on, dropping or hitting the printer.
- Operate the control panel properly. A careless, rough handling may cause problems or malfunction.
Do not use such sharp-edged tool as a ballpoint pen for operation.
- Be careful of the edges of the plates so injury or property damage is possible.
- If a problem occurs during printing, stop the printer immediately and unplug the power cord from the outlet.
- When printer trouble occurs, do not try to disassemble it. Instead, consult our service personnel.

Precautions When Installing the Printer



Caution

- Prior to operation, read the safety instructions carefully and observe them.
- Do not use or store the printer near fire, excessive moisture, in direct sunlight, near an air conditioner or heater or other source of unusually high or low temperature or humidity or excessive dust.
- Do not place the printer where chemical reactions occur, such as in a laboratory.
- Do not place the printer where air is mixed with salt or gas.
- The printer must sit on a firm, level surface where there is ample ventilation. Never allow the printer's air vent to be blocked by a wall or other object.
- Do not put anything on the top of printer.
- Do not place the printer near a radio or television, and do not use the same wall outlet for the printer and radio or television. Radio or television reception could be adversely affected.
- Use the power cord supplied with the product. Never use the power cord for other product.
- Do not put anything on the power cord or step on it.
- Do not drag or carry the printer with the power cord or interface cable.
- Avoid plugging the power cord into an outlet with many loads.
- Do not bundle the power cord when inserting the plug.
- Always grip the plug housing, not the cord, to plug/unplug the power cord.
- Make certain the power is turned off before connecting/disconnecting the interface cable.
- Avoid lengthening the signal cable or connecting it to any noise-producing device. If it is unavoidable, use the shielded cable or twisted pair for each signal.
- Place the printer near the outlet where the power cord can be unplugged easily to shut off power.
- Use the AC outlet that accepts a three-pronged plug. Otherwise, static electricity may be generated and there will be danger of electric shock.

THE TABLE OF CONTENTS

1. INTRODUCTION	17
1.1 Main Features	17
2. Setup	19
2.1 Part Names and Functions	19
2.2 Connection to Power	26
2.3 Driver Installation	27
2.4 Connection to a Computer	28
3. Printer Operation	29
3.1 Power ON/OFF	29
3.2 Normal Operating Mode	30
3.3 LED Functions	32
3.4 Table of Alarm and Error Indications	33
3.5 List of Status Display Contents	34
3.6 Setting the Media	35
3.7 Setting the Ribbon	46
3.8 Mode Settings	50
3.9 Emulation Auto-Detection	85
3.10 Calibrating the Touch Panel	87
3.11 Setting the menu for the Rewinder (CL-S700 III R / CL-S703 III R only)	88
4. Printer Adjustments	89
4.1 Sensor Adjustments	89
4.2 Media Thickness Adjustment	96
4.3 Media Width Adjustment	98
4.4 Adjusting the Ribbon	100
4.5 Adjustable Sensor Position Adjustment	103
4.6 Cleaning	104
5. Troubleshooting	106
6. Appendixes	110
6.1 Specifications	110
6.2 Interfaces	119

1. INTRODUCTION

Thank you for purchasing the Citizen Thermal Transfer Printer. This printer is a product that can be used for labels, tags, tickets, and many other applications.

1.1 Main Features

<Color Touch Panel>

A color touch panel is provided as the control panel. Ease of use has been greatly improved by using GUI operations. Also, when there is an error or alert, the corrective action is displayed with an illustration, so that more intuitive operation is enabled.

<Easy Access – Easy Operation>

The printer is designed for all day-to-day operations to be accessible from the front of the printer so there is no need to move items near to the printer for access for media loading. The power switch is located in a recessed panel at the front of the printer so it can be easily accessed without moving the printer.

<Space-Saving Printer Design>

The top cover on the control panel side opens widely, directly upward, so it does not require extra space on the side of the printer. Also, when replacing the media (labels) or ribbons, the top cover can be opened and closed without moving anything around the printer.

<The Easiest Media Loading>

The Hi-Lift™ metal print head mechanism opens so that it is completely clear of the media path so that the paper and ribbons can be loaded without any part of the printer in the way.

<Flexible Media Usage>

The printer features an adjustable media sensor which allows the customer to use any type of media. The media (label) rolls can be inside or outside would. Similarly, the ink ribbon can be wound either way: 'ink in' or 'in out'.

<Optimum Ribbon Tension>

The patented ARCP™ function – Active Ribbon Control and Positioning – maintains even ribbon tension from beginning to end of a ribbon. This eliminates ribbon wrinkle and improves print positioning, especially for small labels. Smudging caused by ribbon slippage is also removed.

<Multi Programming Language>

This printer contains the Datamax®, Zebra® and Eltron® emulations and will automatically detect the language using the Cross-Emulation™ feature.

<Interfaces and Options>

In addition to USB, an Ethernet interface is provided as standard. In addition, optional interfaces can be installed. Serial, parallel, and wired/wireless LAN optional interfaces are available. In addition, an auto-cutter/peeling unit can be used as an option.

<USB Host Function Provided as Standard>

A USB memory or barcode scanner can be connected for importing data, so standalone printing (Forms Printing) can be carried out. In addition, saving and updating settings/updating firmware/registering printing templates can be performed easily using a USB memory.

<Print Preview Function>

Before printing, the print image can be simply displayed on the color touch panel for checking.

<Easy Rewinder operation> (CL-S700 III R / CL-S703 III R only)

A built-in rewinder can be accessed from the control panel side of the printer, so the backing paper can be easily wound up.

2. Setup

2.1 Part Names and Functions

Inside the printer

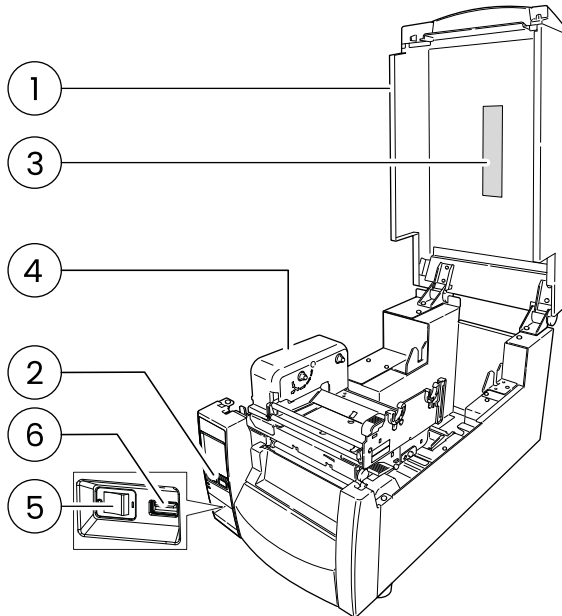

1: Top cover

Is opened vertically to set media or ribbon.

2: Operation panel

This is used to make changes and adjustments to the printer and its configuration.



Refer to Operation Panel

3: Top cover window

The amount of ribbon and media remaining can be checked through this window.

4: Ribbon drive unit



Refer to 3.7 Setting the Ribbon

5: Power switch

This is the power switch for the printer.



Refer to 3.1 Power ON/OFF

6: USB host connector

This is used to connect a USB memory or barcode scanner.

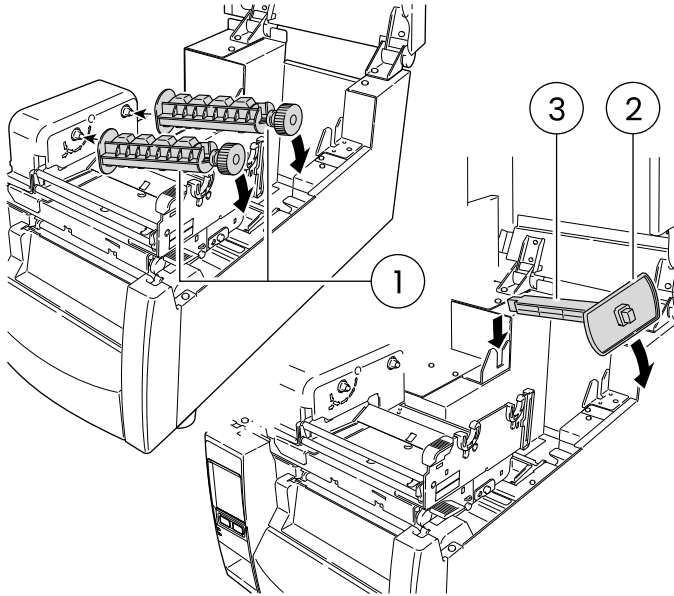

1: Ribbon holder

It is used to attach the ribbon and paper core.

2: Media holder guide

This guide is moved horizontally to match the media size.

The guide can be sliding it from the holder bar.

3: Media holder bar

The media is supported by the media holder bar when installed in the printer.

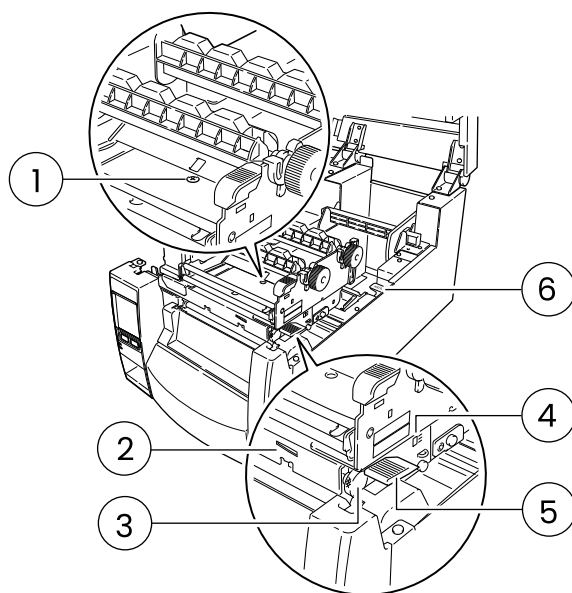

1: Media thickness adjustment screw

It is adjusted to match the thickness of the media.



Refer to 4.2 Media Thickness Adjustment

2: Media width adjustment indicator

3: Media width adjustment knob

It is adjusted to match the width of the media.



Refer to 4.3 Media Width Adjustment

4: Media thickness adjustment indicator

5: Head open lever

The head unit can be raised to install media by pushing this lever.

It locks the head unit during printing.

6: Sensor arm open lever

The sensor arm can be raised to install media by pushing this lever.

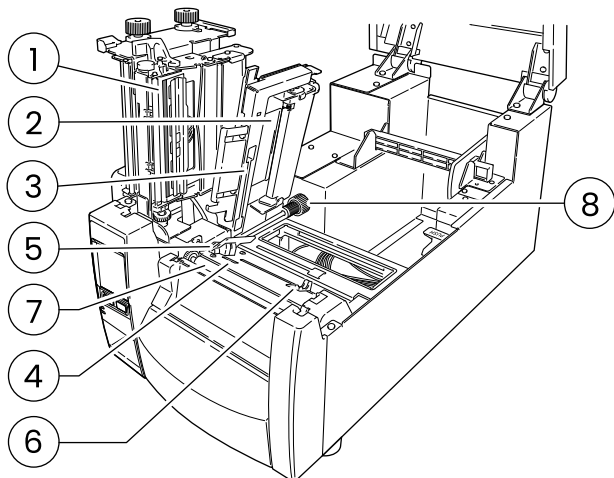

1: Thermal printhead

This is the printhead. Avoid touching this with your fingertips and leaving grease or dirt on the printhead surface.

2: Sensor arm

The media can be installed by raising this arm. The media can be held in place by lowering this arm.

3: Adjustable (rear) sensor

Detects the label or tag position.



Refer to 4.1 Sensor Adjustments

4: Fixed media sensor

Alternative method to detect the label or tag position. This sensor is more accurate for small labels as it is closer to the print head.



Refer to 3.6 Setting the Media

5: Left media guide

This is a fixed part of the printer. The left side of the media (labels, tags) as viewed from the front of the printer should be placed against this media guide.

6: Right, movable media guide

Slide the right media guide so that it just touches the media. It should “guide” the media through the printer. It should not hold it firmly otherwise the media will jam.

7: Platen

Interlocked with the thermal printhead, it feeds media backwards or forwards.

8: Adjustable sensor position knob

This is used to change the left-to-right position of the adjustable media sensor across the media. See 4. Printer Adjustments for more details.



Refer to 4. Printer Adjustments

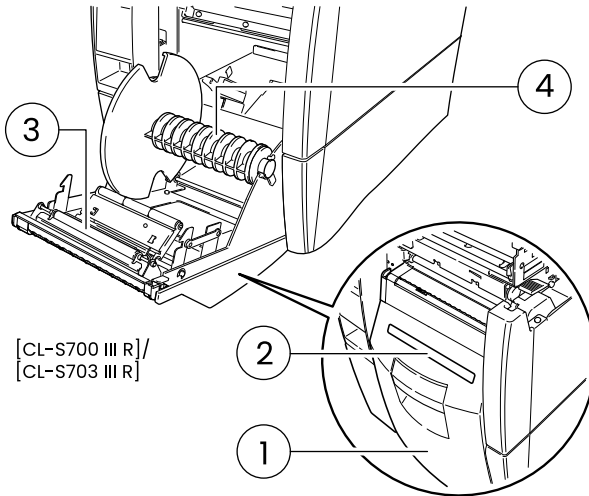

[CL-S700 III R] /
[CL-S703 III R]

1: Rewinder cover

When using the rewinder function, open the door by pulling the opening handle on the front.

2: Media entry slit cover

When using in the winding up mode, remove this cover and pass the media (label) through.

3: Peeler rollers

The labels are peeled from the backing paper one by one.

4: Rewinder flange

The backing paper is wound up.

Operation Panel

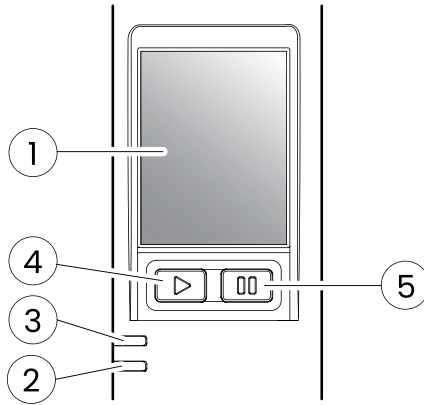

1: LCD display

This displays the operational status of the printer.

2: POWER LED

This is lit when the printer power is on. (green)



Refer to 3.3 LED Functions

3: ERROR LED

This is lit or flashes when the printer is in an alarm or error status. (orange)



Refer to 3.3 LED Functions

4: FEED key

This key feeds the media to the top of the next label or form.

5: PAUSE key

This stops printing or cancels the alarm.

Rear View

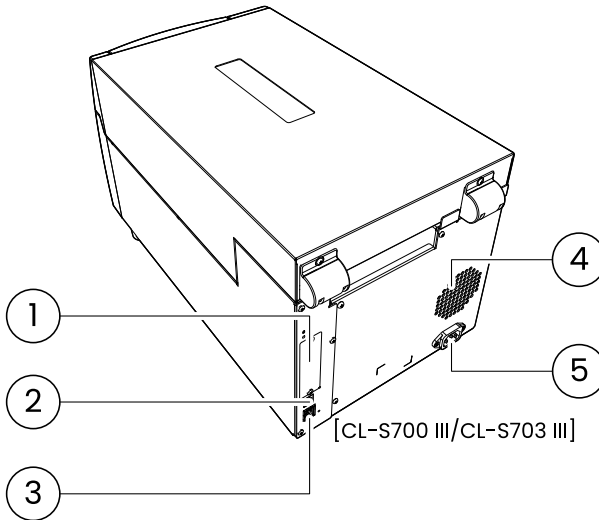

1: Option interface

Optional interface board can be installed by removing the interface cover. Contact your retailer if you want to use the option interface.

 **Refer to Middle-range optional wired LAN/wireless LAN interface (IF1-EFXx, IF1-WFXx)**

 **Refer to High-end optional wired LAN/wireless LAN interface (IF1-ESxx)**

2: USB interface (USB2.0)

This receives USB transmission of data from a host computer.

 **Refer to USB Interface**

3: Wired LAN interface

Data from the host computer is received via wired LAN communication.

 **Refer to Wired LAN interface**

4: Heat air opening

It allows warm air to vent from the printer.

Be sure not to block it with media etc.

5: Power cord inlet

The connector of the enclosed power cord is connected here.



Refer to 2.2 Connection to Power

2.2 Connection to Power

1. The power switch is located on the front of the printer recessed below the control panel. Check that the power switch is turned OFF.
2. Insert the power cord in to the inlet on the printer.
3. Insert the plug of the power cord in the AC outlet.

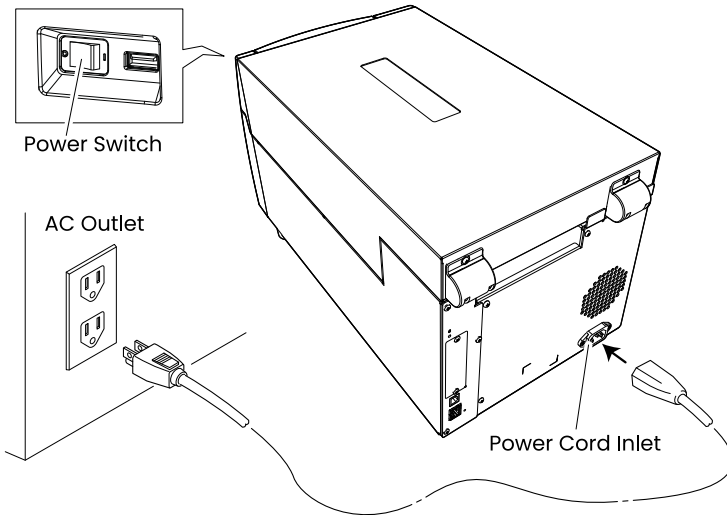

Caution

Use an AC outlet that accepts a three-pronged plug. Otherwise, static electricity may be generated and there will be danger of electric shock.

2.3 Driver Installation

Install the printer driver onto the host computer. Printer drivers are available for download from the Citizen Systems support website. The latest documentation, drivers, utilities, and other support information are also available from this website.

<https://www.citizen-systems.co.jp/en/printer/download/>

Once a printer driver has been downloaded, follow the on-screen instructions to install the driver.

2.4 Connection to a Computer

1. Turn OFF both power switches of the printer and the computer.
2. Insert the cable into the appropriate interface port at the back of the printer.
Tighten any locking screws to secure the cable.
3. Insert the other end of the cable into the appropriate interface port in the host computer.
Tighten any locking screws to secure the cable.

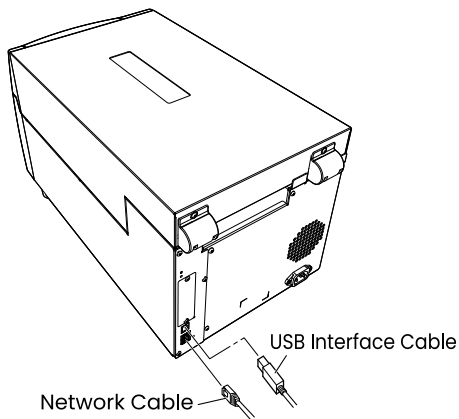

Refer to USB Interface



Refer to Wired LAN interface



Caution

Do not connect a USB cable to the wired LAN interface. Doing so may damage connectors.

Notes

Do not connect multiple interfaces at the same time.

3. Printer Operation

3.1 Power ON/OFF

Turning on the power

1. The power switch is conveniently located at the front of the printer for easy access during normal operation. It is in the recess underneath the control panel so it cannot be accidentally operated by mistake.
2. The POWER LED is lit.

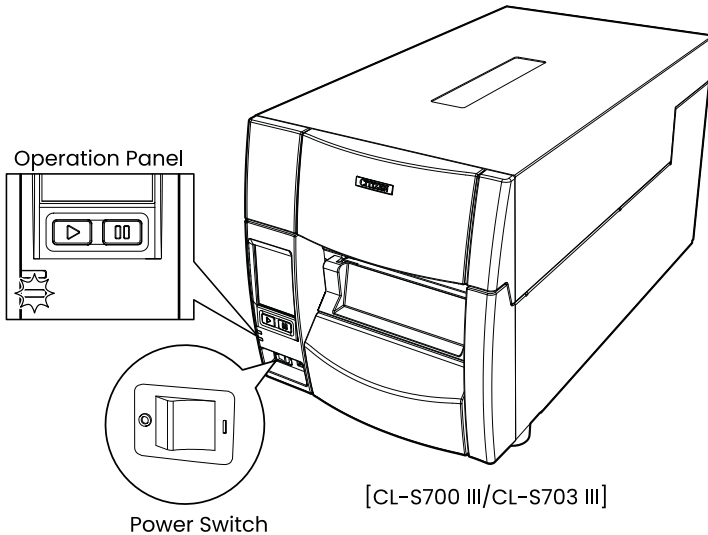

Turning off the power

1. Turn off the power switch of the printer.
2. The POWER LED goes off.

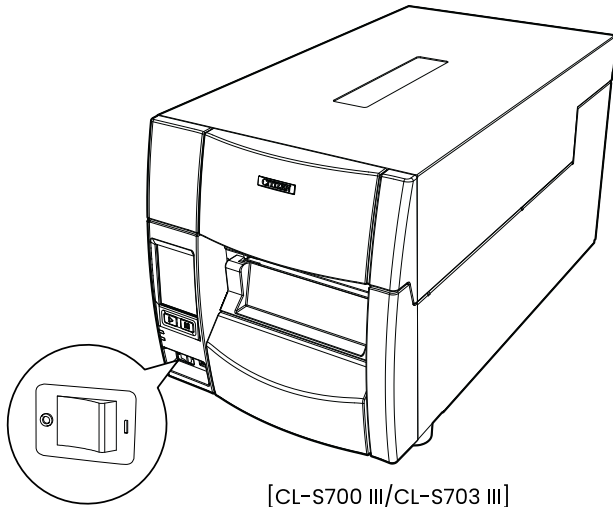

Power Switch

[CL-S700 III/CL-S703 III]

3.2 Normal Operating Mode

When the power is turned on, the printer enters normal operating mode. The control keys activate the following functions.



Refer to Menu settings

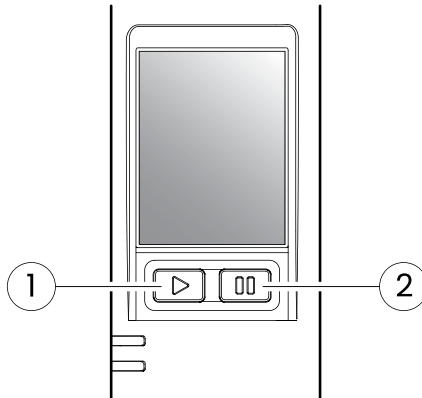

1: FEED key: Feeds media

- Pressing this key feeds media to the print start position. The distance it is fed is determined by automatically detecting the front end of

the media when using label media, and when continuous media has been designated, a fixed quantity is fed, then feeding stops.

- When the TEAR OFF setting is effective, feeding stops when the media has been fed to the TEAR OFF location.
- When the optional cutter unit is installed, the media is fed to the cut position then it is cut.
- If the optional peeler unit is installed, the media is fed to the peeling location. When the media is pausing at the peeling position, feeding does not occur, even if the FEED key is pushed.

2: PAUSE key: It stops printing and cancels the alarm

- When this key is pushed once, the LCD indicates "Pause" and the printer temporarily pauses.
- When this key is pushed once during printing, the printer will pause after printing the label has been completed.
When the key is pushed again, printing is enabled, and the print data that has been received is printed. When the PAUSE key is pushed for four or more seconds while paused, the label print data for one batch can be canceled. (When canceled, "Job canceled" is displayed)
- Pushing this key once cancels the abnormal head resistance alarm.

3.3 LED Functions

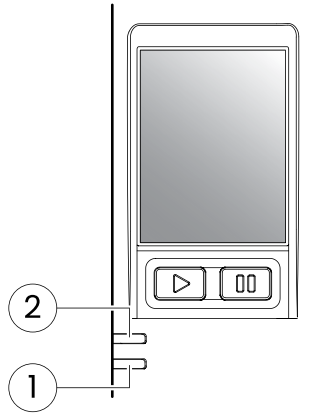

1: POWER LED

It lights up when printer power is turned on. (green)

2: ERROR LED

This is lit or flashes when the printer is in error status. (red)

3.4 Table of Alarm and Error Indications

When an abnormal condition is detected in the printer, an alarm sounds and ERROR LED either lights up or flashes to indicate the type of error. The LCD indicates the error message.

Item	ERROR LED	LCD
Printing possible (no error)	OFF	Ready
Pause key on operation panel pressed	OFF	Pause
Head temperature - high temperature abnormality	Flashing	Head Hot
Head temperature - low temperature abnormality	Flashing	Head Cold
PF motor temperature abnormality	Flashing	PF Motor Hot
Cutter motor temperature abnormality	Flashing	Cut Moter Hot
USB host power supply abnormality	Flashing	USB Host Fail
Head open	Flashing	Head Open
Paper end	Flashing	Paper End
Paper out (paper position undetectable)	Flashing	Paper Load
Paper jam	Flashing	Paper Jam
Head low resistance value abnormality	Flashing	Head Check
Ribbon end	Flashing	Ribbon End
Communication error (receiving buffer overrun)	Flashing	Serial Over Run
Communication error (parity)	Flashing	Serial Parity
Communication error (framing)	Flashing	Serial Framing
Auto-cutter abnormality (foreign object etc.)	Flashing	Cutter Fail
Fan motor malfunction	Flashing	Fan Lock
Rewinder Hot (CL-S700 III R / CL-S703 III R only)	Flashing	Rewinder Hot
Rewinder full (CL-S700 III R / CL-S703 III R only)	Flashing	Rewind Full
Rewinder cover open (CL-S700 III R / CL-S703 III R only)	Flashing	Rewind Open
Rewind fail (CL-S700 III R / CL-S703 III R only)	Flashing	Rewind Fail

3.5 List of Status Display Contents

Icons are displayed on the top of the top screen for items such as the interface during communication, printer operation mode, and connection status of peripheral devices.

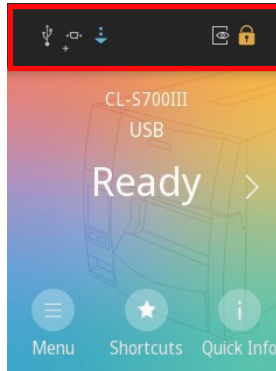

List of Status Display Contents:

Icon	Item details
	Displayed when the printer is receiving data.
	Displayed when the printer built-in USB is connected to an external device.
	Displayed when a LAN cable is connected to the printer built-in wired LAN connector, and communication is enabled in accordance with the IP address.
	Displayed when a wired LAN interface (optional) is installed, and communication is enabled in accordance with the IP address.
	Displayed when a wireless LAN interface (optional) is installed, and communication is enabled in accordance with the IP address.
	Displayed when a serial interface (optional) board is installed on the printer.
	Displayed when a parallel interface (optional) board is installed on the printer.
	Displayed during HEX dump mode.
	Displayed when Preview Mode is set to On.
	Displayed when a USB memory is connected to the printer USB host.
	Displayed when a device such as a scanner is connected to the printer USB host.
	Displayed when the Keyboard Lock is set to On.

3.6 Setting the Media

Media Sizes

The position of label and tag media is sensed by either a label detection sensor (Transparent sensor) or a black mark detection sensor (Reflective sensor).

Label detection sensor (Transparent sensor): Detects the gaps between label media and notches of tag media

Black mark detection sensor (Reflective sensor): Detects the black mark

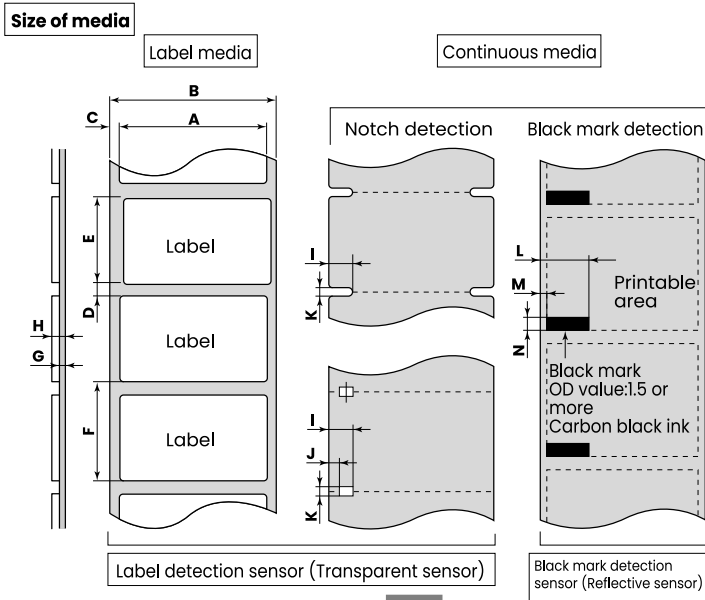

Direction of media feed

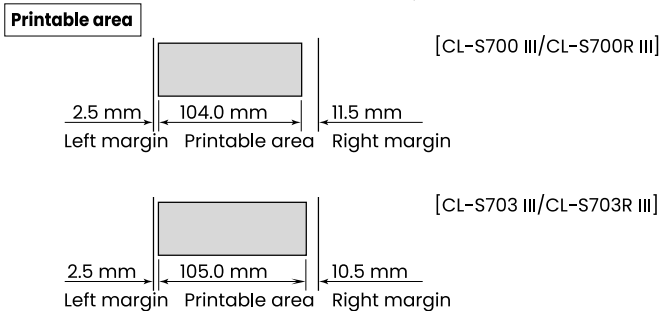

Print Positioning Accuracy

Print positioning accuracy of the head position

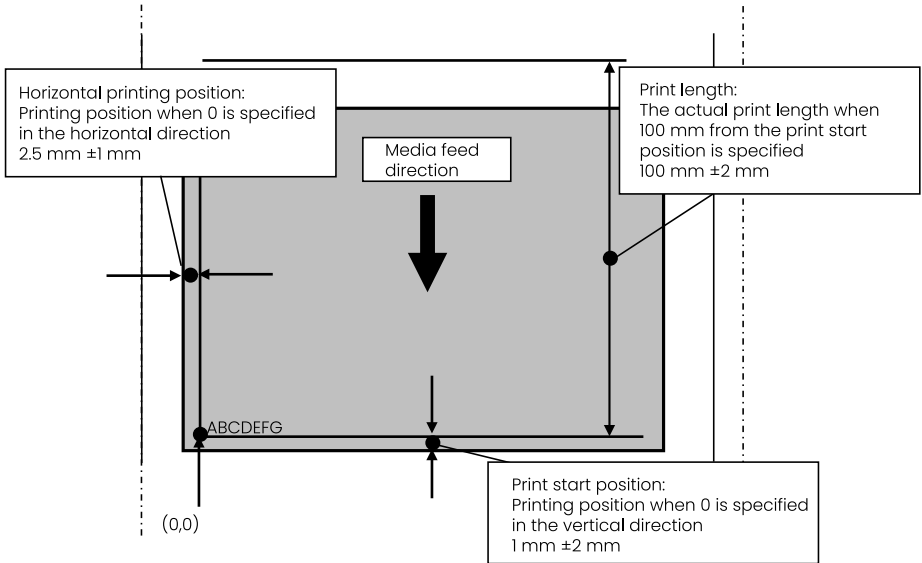

When Using Front Sensors

		Minimum value		Maximum value	
		mm	(inch)	mm	(inch)
A	Label width	7.62	(0.3)	118.00	(4.65)
B	Liner width	25.4	(1.0)	118.00	(4.65)
C	Left end of label	0	(0)	2.54	(0.10)
D	Gap between labels	2.54	(0.10)	2539.70*	(99.99*)
E	Label length	2.54	(0.10)	2539.70*	(99.99*)
F	Label pitch	6.35	(0.25)	2539.70*	(99.99*)
G	Liner thickness	0.06	(0.0025)	0.125	(0.0049)
H	Media thickness	0.06	(0.0025)	0.25	(0.01)
I	Right end of notch	8.3	(0.32)	11	(0.43)
J	Left end of notch	0	(0)	4.7	(0.19)
K	Notch length	2.54	(0.10)	17.80	(0.70)
L	Right end of black mark	15.00	(0.59)	-	-
M	Left end of black mark	0	(0)	1.5	(0.06)
N	Black mark width	3.18	(0.125)	17.80	(0.70)

- Use a label detection sensor (Transparent sensor) for label media gaps and media with black marks.
- Use the continuous media detection sensor (reflective sensor) for continuous media with no notches or black marks.
- Use a label detection sensor (Transparent sensor) for fan fold media.

- If the label pitch is 1 inch or less, set the Small Media Adjustment menu to ON and match it to the label that uses the value of the Small Media Length menu.

* For CL-S703 III / CL-S703 III R, the value is 1625.60 mm (64.00 inch)



Refer to List of Settings

When Using Adjustable Sensor

		Minimum value		Maximum value	
		mm	(inch)	mm	(inch)
A	Label width	25.4	(1.0)	118.00	(4.65)
B	Liner width	25.4	(1.0)	118.00	(4.65)
C	Left end of label	0	(0)	2.54	(0.10)
D	Gap between labels	2.54	(0.10)	2539.70*	(99.99*)
E	Label length	12.70	(0.50)	2539.70*	(99.99*)
F	Label pitch	12.70	(0.50)	2539.70*	(99.99*)
G	Liner thickness	0.06	(0.0025)	0.125	(0.0049)
H	Media thickness	0.06	(0.0025)	0.25	(0.01)
I	Right end of notch	3.6	(0.14)	60.8	(2.39)
J	Left end of notch	0	(0)	57.2	(2.25)
K	Notch length	2.54	(0.10)	17.80	(0.70)
L	Right end of black mark	15.00	(0.59)	66.5	(2.62)
M	Left end of black mark	0	(0)	51.5	(2.02)
N	Black mark width	3.18	(0.125)	17.80	(0.70)

- Use a label detection sensor (Transparent sensor) for label media gaps and media with black marks.
- Use the continuous media detection sensor (reflective sensor) for continuous media with no notches or black marks.
- Use a label detection sensor (Transparent sensor) for fan fold media.
- If the label pitch is 1 inch or less, set the Small Media Adjustment menu to ON and match it to the label that uses the value of the Small Media Length menu.

* For CL-S703 III / CL-S703 III R, the value is 1625.60 mm (64.00 inch)



Refer to List of Settings

Loading roll media

1. Push the large blue head-open lever to release the head unit, and then lift the sensor arm by hand as shown below.

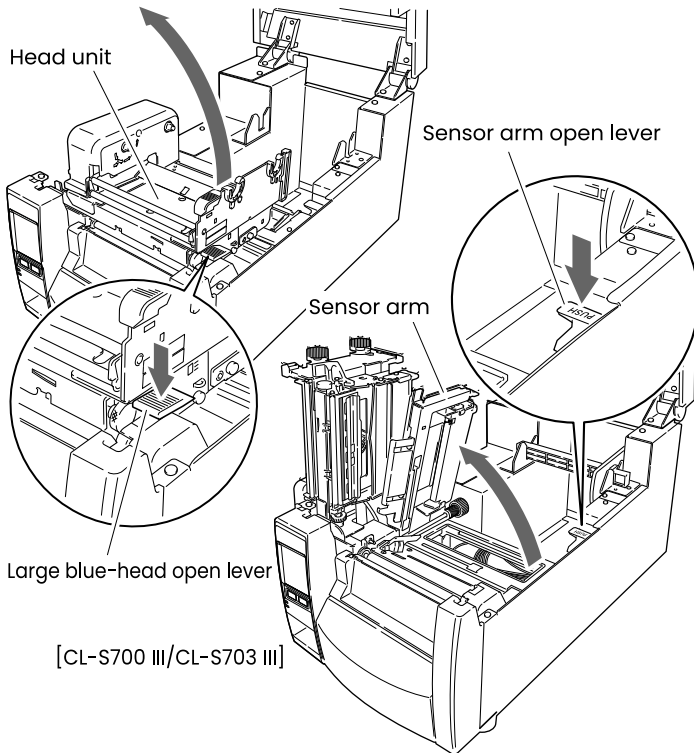

Caution

Note the following precautions when the head unit is open.

- Do not touch the thermal head.

2. Firstly, slide the two black plastic parts of the media holder assembly together. Ensure correct alignment of the guide with the bar as it can only be installed in one direction.

- Slide the roll of media over the media bar. The media guide must be on the right side of the roll of media (as viewed from the front of the printer) with the flat surface of the media guide touching the roll.

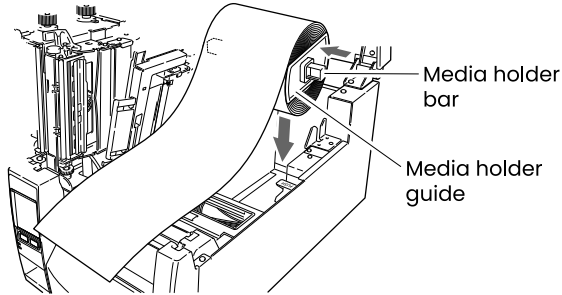

Refer to Media Sizes

- Set the media roll and media holder in to the printer as shown above. It is advisable to pull a length of media forwards and through the mechanism ready for later positioning.
- Move the media roll so it is touching the left side of the housing. Then slide the black movable media guide so it is touching the media on the right side.



Caution

Do not try to hold the media too tightly with these guides as it will cause the printer to jam during printing.

- Align the media with the left fixed media guide (2 locations), align the right movable media guide with the media width, and lower the sensor arm which loosely holds the media in position.

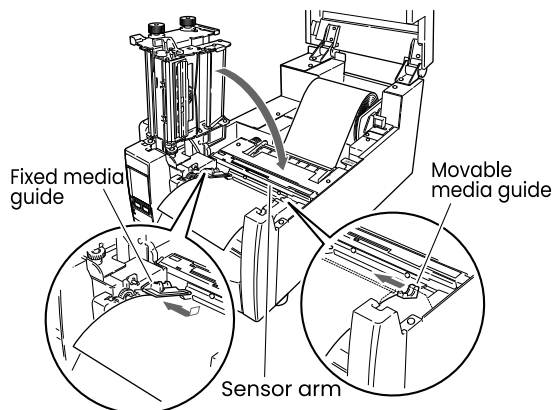

7. Lower the head unit back down to the closed position. Push the head close knob firmly to close and lock the mechanism.

The mechanism is only locked correctly when you head a “click”.

Align it with the width of the media that has been set, then set the media width adjustment screw and the media thickness adjustment knob. See “4. Printer Adjustments”.

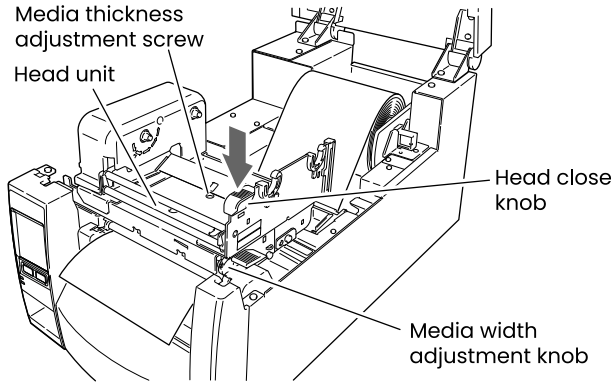

Refer to 4.2 Media Thickness Adjustment



Refer to 4.3 Media Width Adjustment

8. Selecting the sensor

Select the sensor to be used from “Setup” on the menu screen -> “Sensor Setup” -> “Media Sensor.”



Refer to Menu settings

9. Push the FEED key to feed the media. It will halt at the next print start position.

Loading fanfold media

1. Push the large blue head-open lever to release the head unit, and then lift the sensor arm by hand as shown below.

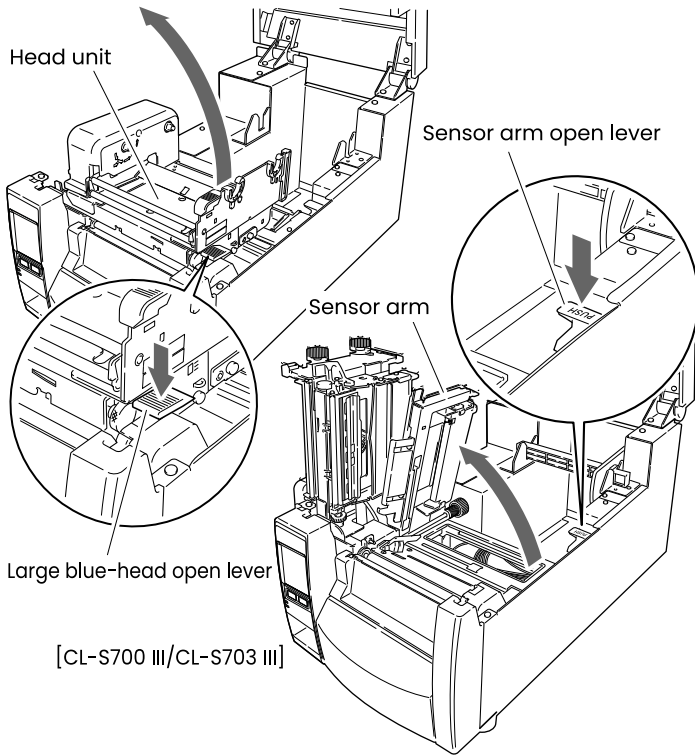

Caution

Note the following precautions when the head unit is open.

- Do not touch the thermal head.

2. Insert the fanfold media through from the external media feed port at the back of the printer.

3. Leaving the specified gap from the printer, place the fanfold paper so that it is at the same height as the printer and becomes parallel with the printer as shown in the figures below.

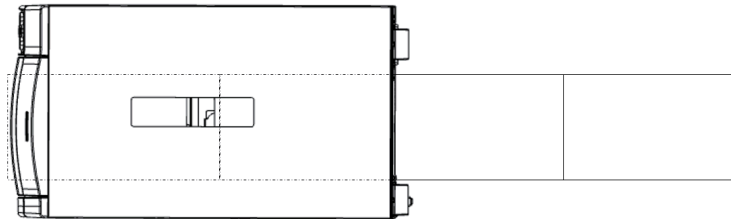
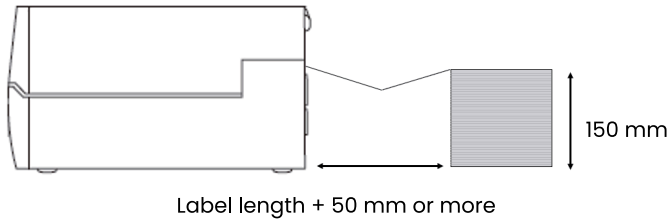

Place the fanfold media so that it is parallel with the printer.

4. Insert the fanfold media through below media holder bar and set the holder by aligning it with the media width.

Caution

Do not try to hold the media too tightly with these guides as it will cause the printer to jam during printing.

5. Align the media with the left fixed media guide (2 locations), align the right movable media guide with the media width, and lower the sensor arm which loosely holds the media in position.
6. Lower the head unit back down to the closed position. Push the head close knob firmly to close and lock the mechanism.
- The mechanism is only locked correctly when you head a "click".
- Align it with the width of the media that has been set, then set the media width adjustment screw and the media thickness adjustment knob. See "Chapter 3 Printer Adjustments".



Refer to 4.2 Media Thickness Adjustment



Refer to 4.3 Media Width Adjustment

7. Selecting the sensor

Select the sensor to be used from "Setup" on the menu screen -> "Sensor Setup"
-> "Media Sensor."



Refer to Menu settings

8. Push the FEED key to feed the media. It will halt at the next print start position.

Cut position of media with a perforated line

When tearing manually, the media can be torn at the position of the perforated line.

When adjusting the paper stop position, set the vertical printing position to a value larger than the media stop position. Otherwise, the media may come off the platen during back feeding.

Adjust each setting using the printer driver or LabelPrinterUtility.

Using the Rewinder as a Peeler (CL-S700 III R / CL-S703 III R models/Peeling Mode)

1. Open the rewriter cover and remove the rewriter flange.

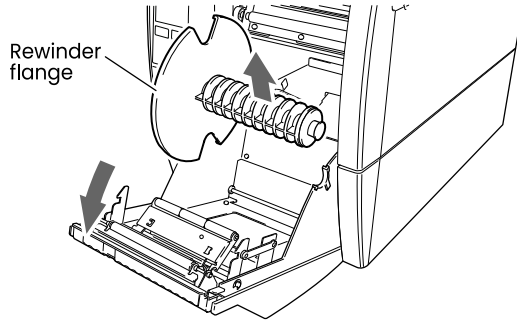

2. Pull out approximately 40cm length of the media from the head unit.

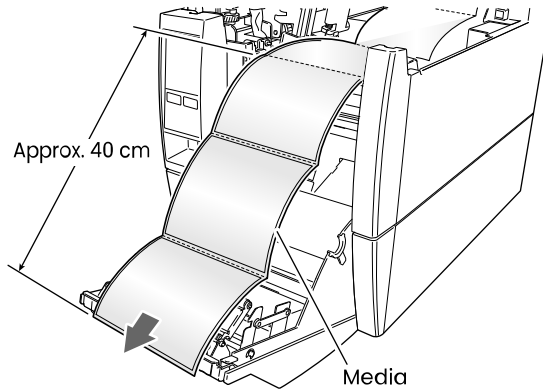

3. Peel off a number of labels at the tip part of the media from the liner so that the liner unit is in contact with the peeler roller when closing the rewriter cover.

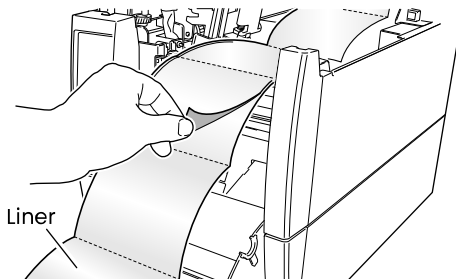

4. Insert the end of the liner in to the slot in the rewriter flange and wind the liner on to itself with two or three turns to ensure it is held properly. Set the rewriter flange back in to the printer.

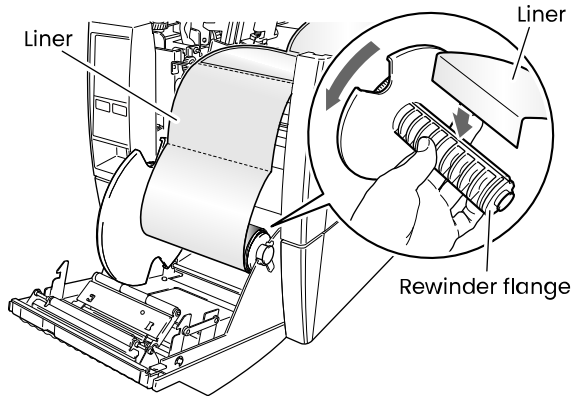

5. Confirm that the liner unit is in place in the peeler roller and close the rewriter cover.

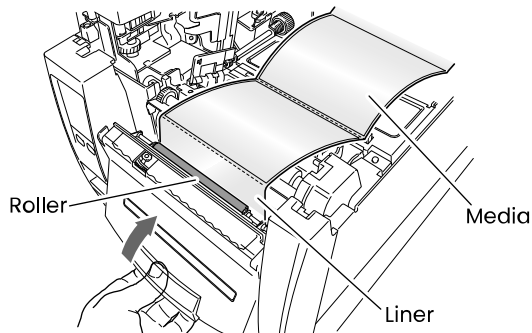

 **Refer to Loading roll media**



Caution

When closing the rewriter cover, be careful not to catch any foreign objects or fingers in the mechanism.

3.7 Setting the Ribbon

The following kinds and sizes of ribbons can be used.

Types	Inside wound and outside wound ribbon
Max. ribbon width	114.0 mm (4.50 inch)
Min. ribbon width	25.4 mm (1.00 inch)
Max. ribbon length	450.0 m (1,476 ft)
Max. roll diameter	86.5 mm (3.40 inch)
Inner diameter of the paper core	25.4 ±0.25 mm (1.00 ±0.01 inch)
Lead tape length	Less than 80 mm

Setting method

1. Place the attached ribbon and paper core separately on one of the two attached ribbon holders.

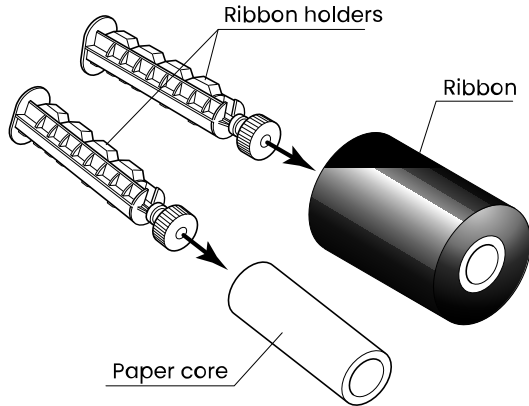

Notes

- Insert the two ribbon holders into the ribbon and paper cores ensuring that they are pushed in all the way.
- Use of ribbon with a width that is at least +10% wider than the width of the media to be used is recommended.
- If using media with a width of 2 inches or less, we recommend using a 60-mm or wider ribbon.

2. Install the unused ribbon and holder in to the rear ribbon drive unit. The splines on the ribbon drive gear mechanism engage with the end of the ribbon holder.

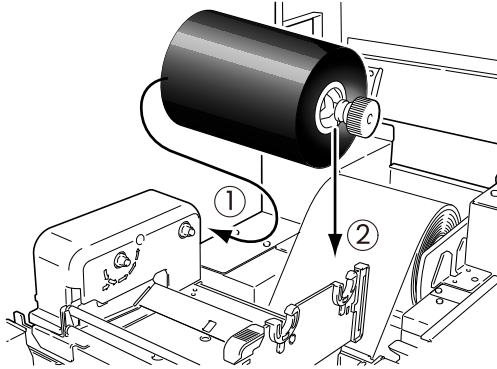

3. Push the large blue head-open lever to release the head unit. Pull out the ribbon from the bottom of the head unit to the ribbon winding side.

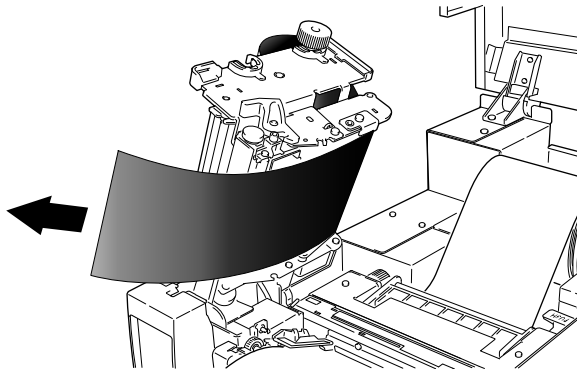

4. Using tape etc., fix the ribbon that you have pulled out on the ribbon holder on which the paper core has been set and wind it on the ribbon holder.

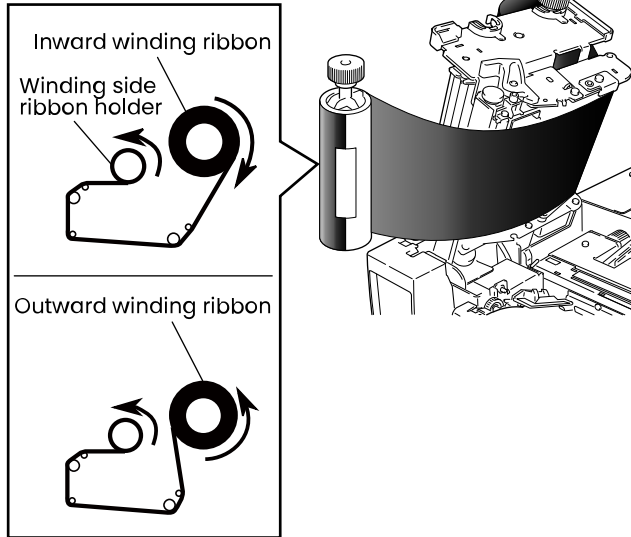

5. Set the ribbon holder on which the paper core has been set in the ribbon drive unit, then rotate it in the direction shown by the arrow to remove slack and wrinkles from the ribbon.

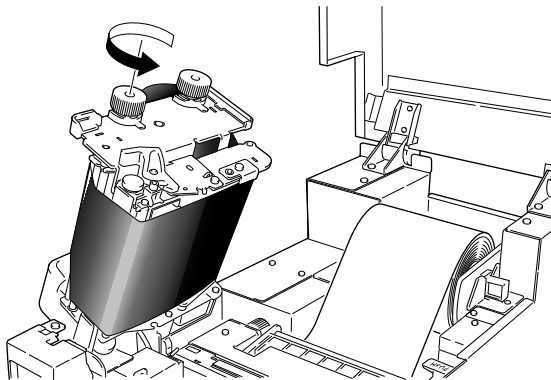

6. Lower the head unit back down to the closed position. Push the head close knob firmly to close and lock the mechanism.

The mechanism is only locked correctly when you heard a “click”. If the ribbon is wrinkled, push the FEED key until the wrinkles disappear. If the wrinkles do not disappear or if it slips, perform ribbon tension adjustment and media width adjustment. See “4. Printer Adjustments” for these adjustment methods.

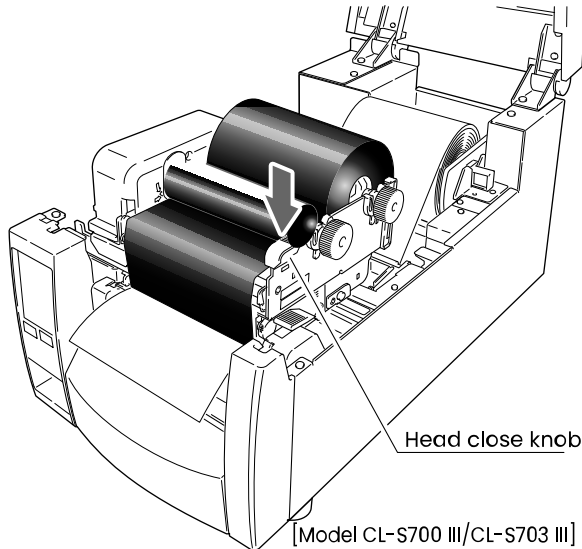

Refer to 4.4 Adjusting the Ribbon



Refer to 4.3 Media Width Adjustment

3.8 Mode Settings

If the power supply is turned on while pushing the PAUSE key, the following function is executed, and the printer goes into the User Test mode.

By pressing the “Menu” button on the “User Test” top screen, the “User Test” menu screen for executing the various functions is displayed.

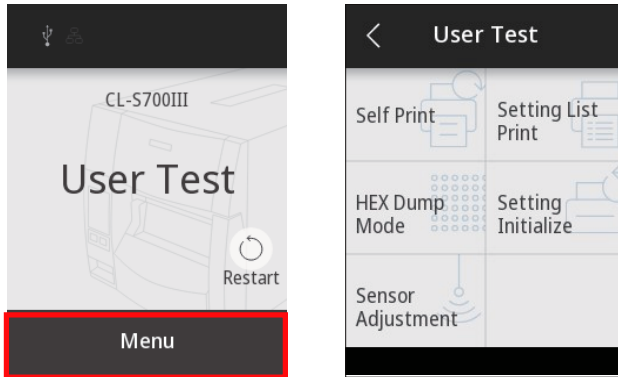

Self Print

This mode is for performing self-test printing. Self-test printing is an easy way to check the printer settings and the print quality.

Press the “Self Print” button on the “User Test” menu screen, load the media (labels), and then perform the following procedure.

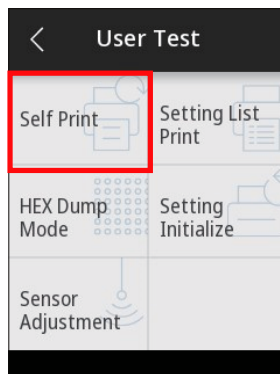

When using label media

After selecting “See Through” or “Reflect,” press the “OK” button at the bottom of the screen. Then, press the “Print” button on the screen displayed, and the test pattern will be printed.

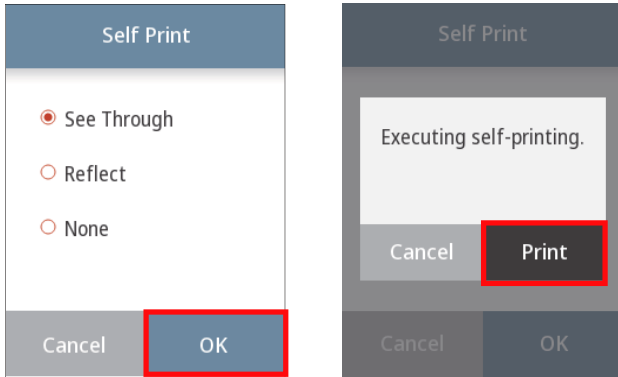

When using continuous media

After selecting “None,” press the “OK” button at the bottom of the screen. Then, press the “Print” button on the screen displayed, and the test pattern will be printed.

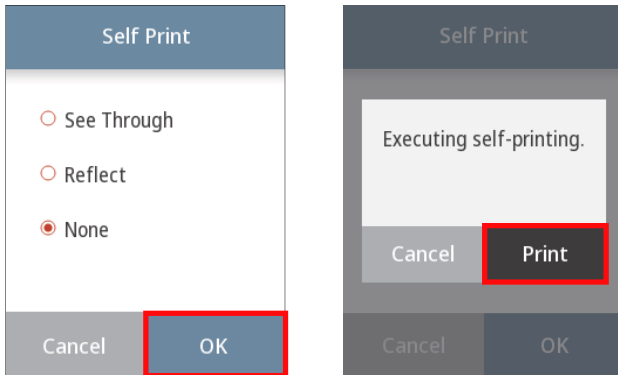

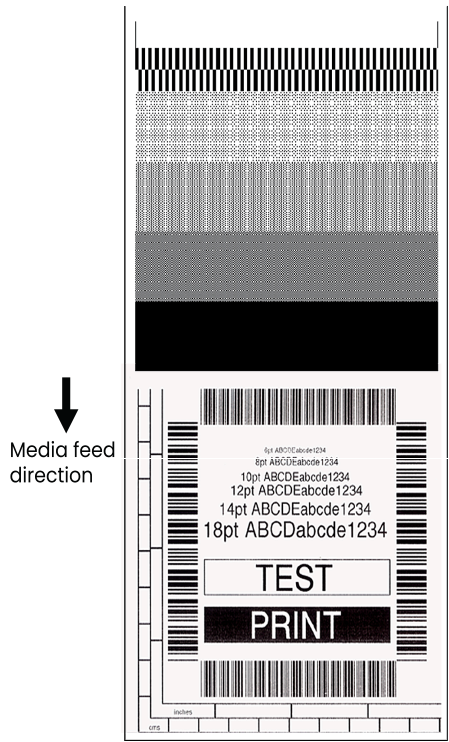

Using the Self Test Print shown above, you can make adjustments to the printer settings such as media width and media thickness (printhead pressure). For more details of the adjustment, refer to “4. Printer Adjustments.”

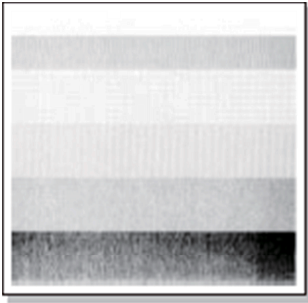

The first sample, left, shows an incorrectly set “media thickness adjustment”. For standard label media, the media thickness adjustment indicator should be set to the center scale in the window.

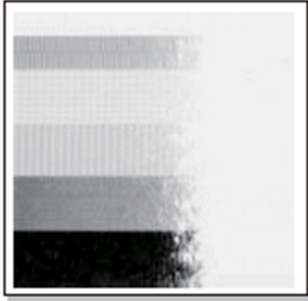

The second sample, left, shows an incorrectly set “media width adjustment”. For 4-inch or 100 mm wide media, the adjuster should be set to the scale of 100 mm in the window. The settings shown above are for general label media and may not apply to specialist media.



Refer to 4.3 Media Width Adjustment



Refer to 4.2 Media Thickness Adjustment

HEX Dump Mode

This mode is used to print a hex dump list (data received by the printer represented in hex values) for confirmation of the data content.

Press the “HEX Dump Mode” button on the “User Test” menu screen, load the media (labels), and then perform the following procedure.

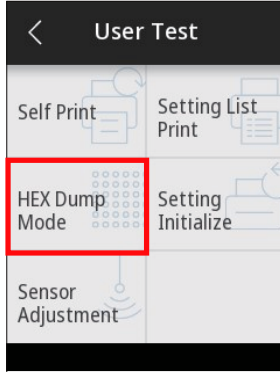

When using label media

After selecting “See Through” or “Reflect,” press the “OK” button at the bottom of the screen. Then, press the “OK” button on the screen displayed.

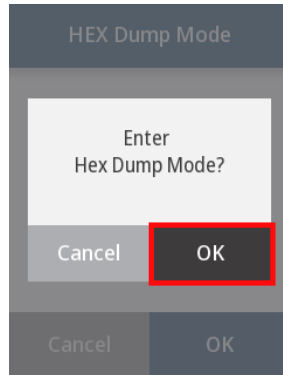
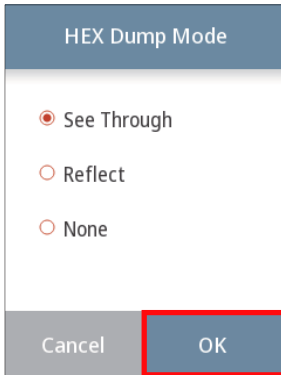

When using continuous media

After selecting “None,” press the “OK” button at the bottom of the screen. Then, press the “OK” button on the screen displayed.

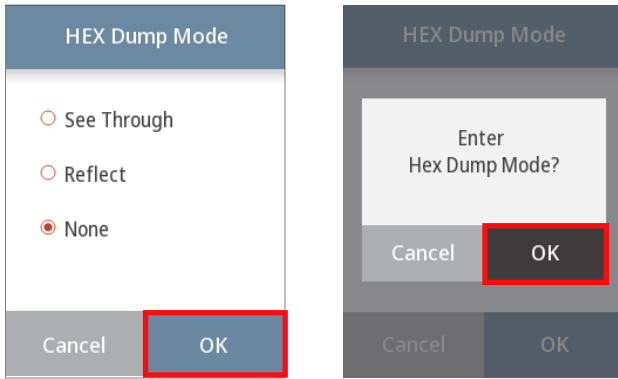

Example of dump list printing

DUMP LIST

```
02 40 30 31 30 30 0D 02 60 30 30 32 30 0D 02 4C .M0100. .c0020. .L
44 31 31 0D 31 30 30 30 30 30 30 30 30 30 31 30 D11.100000000010
30 30 31 30 31 32 33 34 35 36 37 38 39 3A 3B 3C 0010123456789::<
```

* To exit HEX Dump Mode, turn off the power to the printer then turn the power on again (restart).

Printing a List of Settings

A list of the setting values can be printed for checking.

Press the “Setting List Print” button on the “User Test” menu screen, and after selecting “Current Setting,” press the “OK” button at the bottom of the screen. Then, press the “Print” button on the screen displayed.

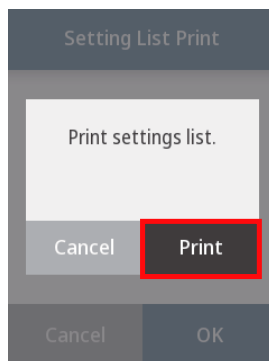
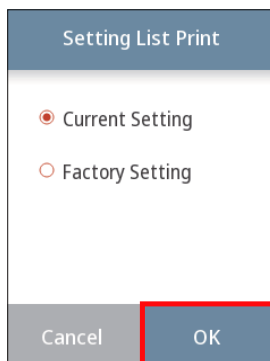
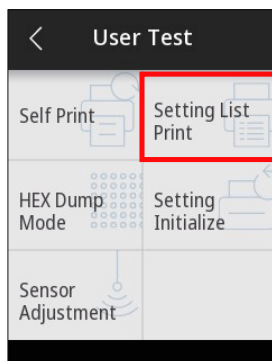

Machine Information	
Model Number	: CL-S700 III
Boot Version	: ****
ROM Version	: ****
ROM Date(DD//MM//YY)	: 07/10/03
ROMCheck Sum	: ****
FPGA Version	: *** **
Head Check	: OK
Print Counter	: 0002.234km
Service Counter	: 0002.234km
Cut Counter	: 0
Sensor Monitor	: 1.50V
Option Interface	: None
MAC Address	: **.*.*.*.*.*.*.*.*.*
Current Menu Setting	
[Global Config Menu]	
Config Set	: 1
[PageSetup Menu]	
Print Speed	: 7 IPS
Print Darkness	: 12
Darkness Adjust	: 00
Print Method	: Thermal Transfer
Continuous Media Length	: 4.00 inch
Vertical Position	: 0.00 inch
Horizontal Shift	: 0.00 inch
Vertical Image Shift	: 0.00 inch
Small Media Adjustment	: Off
Small Media Length	: 1.00 inch

* If the double heat function is enabled, the value doubles.

This function reduces print fading. To enable this function, configure the setting via Windows driver properties or LabelPrinterUtility. See the respective manual for how to configure the setting.

Notes

Citizen continually enhances its printers with new options and settings based on our customer's requests. Extra or changed menu items may appear on the above print out in some cases.

Settings initialization

This mode is used to initialize printer settings and the user memory area. Press the "Settings Initialize" button on the "User Test" menu screen, and press the "Initialize" button on the screen displayed.

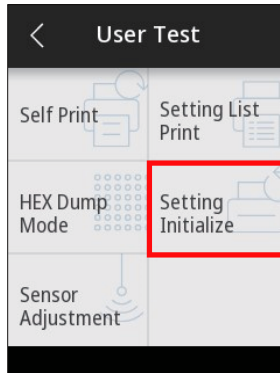

Menu settings

Press the “Menu” button at the bottom of the top screen while printing is enabled, and enter the “Menu” screen. Using touch operations on the operation panel, the details of the current settings can be checked, and the setting details of each item can be changed.

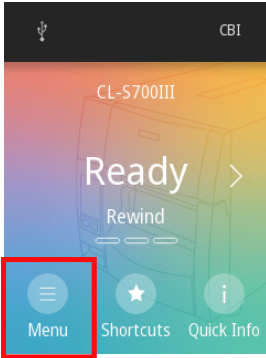

Top screen

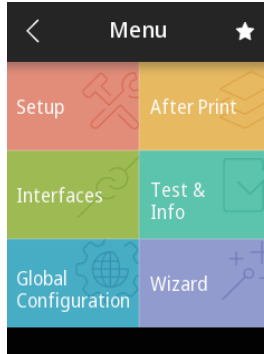

Menu screen

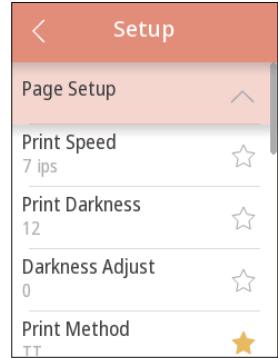

Sub menu screen

Menu	Sub Menu	Description
Setup	Page Setup	Display/Change print settings
	Sensor Setup	Display/Change the various sensor settings
	System Setup	Display/Change the system settings
	Locking Setup	Display/Change the operation restriction settings
	Standalone Forms	Setting/Managing of Standalone Forms
After Print	-	Display/Change the settings for operations after printing
Interfaces	Interface	Display/Change the interface settings
	Option Interface	Display/Change the optional interface settings
Test & Info	Test Mode	Printer operation test mode
	Machine-Info	Printer information display
Global Configuration	-	Display/Change the configuration number
Wizard	-	Printer settings using the wizard

Example of changing setting values

The following is an explanation of how to change the setting value of “Print Darkness” in “Page Setup” from “12” to “13.”

1. Select “Setup” from the “Menu” screen to display the sub-menu list.

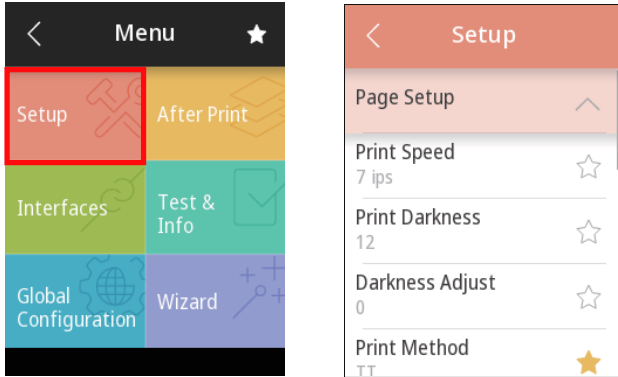

2. From “Page Setup,” select “Print Darkness.” The current setting value “12” is displayed.



Function of each button

+ button	Displays a value greater than the current value (in this case, 13).
- button	Displays a value lower than the current value (in this case, 11).
OK button	The current value is temporarily saved.
Cancel button	“Print Darkness” is exited. The value is not changed.

3. Press the + button once to change the value to "13," then press the "OK" button at the bottom of the screen.

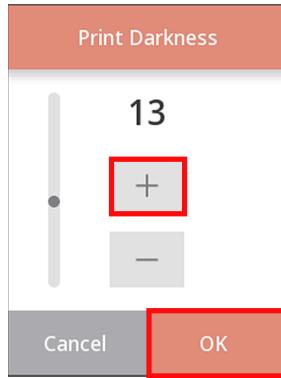

Save the setting

When a setting change requires the printer to be restarted, a screen to select Reboot is displayed before returning to the top screen.

Press "Reboot" to restart the printer.

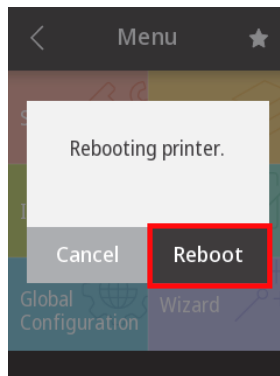

List of Settings

Press the “Menu” button on the top screen while printing is enabled, and enter the “Menu” screen. Using touch operations on the operation panel, carry out the printer settings.

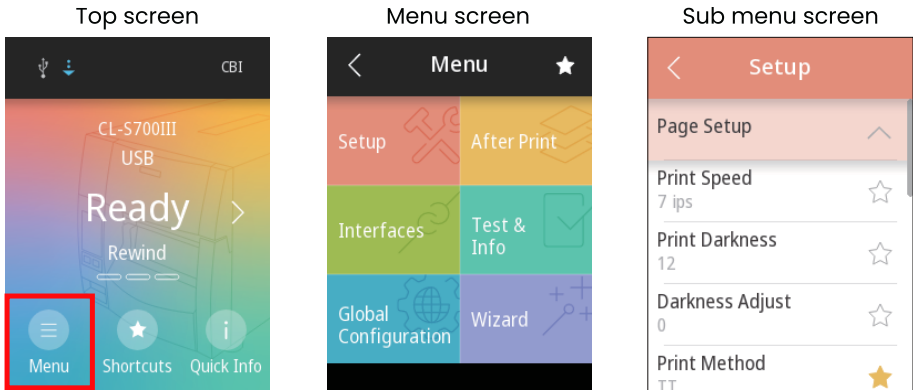

The details that can be set on the printer are as follows.

Menu: Setup → Page Setup

Sub Menu		Default	Configurable range	Remarks
Print Speed	CL-S700 III	7 IPS	When the print preference is darkness 2 to 10 IPS When the preference is speed 2 to 12 IPS	Printing speed setting The range that can be set varies depending on the print preference. (CL-S700 III / CL-S703 III)
	CL-S703 III	7 IPS	When the print preference is darkness 2 to 8 IPS When the preference is speed 2 to 10 IPS	
	CL-S700 III R	7 IPS	2 to 10 IPS	
	CL-S703 III R	7 IPS	2 to 8 IPS	
Print Darkness		DM4: 12 DMI: 12 DPP: 11 ZPI2: 12 EPI2: 7	DM4: 0 to 30 DMI: 0 to 30 DPP: 0 to 20 ZPI2: 0 to 30 EPI2: 0 to 15	Adjusting print darkness.
Darkness Adjust		00	-10 to 10	Fine adjustment of darkness commands.

Sub Menu		Default	Configurable range	Remarks
Print Preference		Darkness	Darkness / Speed	Select which setting to be given more weight during printing, print darkness or printing speed. Switching to high-speed priority may affect print quality. If readability or bar code reading accuracy is a priority for your operations, return the setting to darkness priority.
Print Method		TT	TT / DT	Selection of Thermal Transfer (ribbon) or Direct Thermal.
Double Heat		Off	On / Off	Double heat setting
Continuous Media Length	CL-S700 III/ CL-S700 III R	4.00 inch 101.6 mm	0.25 to 99.99 inch 6.4 to 2539.7 mm	Setting media length of continuous media. Lower level = during mm mode.
	CL-S703 III/ CL-S703 III R	4.00 inch 101.6 mm	0.25 to 64.00 inch 6.4 to 1625.6 mm	Setting media length of continuous media. Lower level = during mm mode.
Vertical Position		0.00 inch / 0.0 mm	-1.00 to 1.00 inch / -25.4 to 25.4 mm	Adjusting printing start position.
Horizontal Shift		0.00 inch / 0.0 mm	-1.00 to 1.00 inch / -25.4 to 25.4 mm	Adjusting horizontal image position.
Vertical Image Shift	Data-max®	0.00 inch / 0.0 mm	0.00 to 32.00 inch / 0.0 to 812.8 mm	Adjusts the start position for creating images
	Zebra® / Eltron®	000 dots	-120 to 120 dots	
Small Media Adjustment		Off	On / Off	Setting for small label support
Small Media Length		1.00 inch / 25.4 mm	0.25 to 1.00 inch / 6.4 to 25.4 mm	Sets the length for small label media

System Setup

Sub Menu	Default	Configurable range	Remarks
Error Reporting	On Printing	On Printing / Immediate	Setting for error report.
Buzzer Select	Exec/Err	Exec/Err All Error Key None	Setting buzzer sounding conditions.
Metric/Inch Select	Inch	Inch / mm	Sets the units.
Max Media Length	10.00 inch / 254.0 mm	1.00 to 99.99 inch / 25.4 to 2539.7 mm	Sets the maximum media length.
LCD Brightness	100%	10 to 100%	Adjusting LCD brightness

Sub Menu	Default	Configurable range	Remarks
LCD Standby	Off	On / Off	LCD standby selection Select whether to turn off the LCD during the standby mode.
Standby Timer	5 min	1 to 99 min	Set the time before going into the standby mode
Control Code	STD	STD / ALT / ALT-2	Switches command mode of DMX mode. (Only when Datamax® emulation is selected)
Media Power Up	Off	On / Off	Set the media length measurement function when the power supply is On (Only when Zebra® emulation is selected)
Emulation Select	DM4 (Datamax®) ZPI2 (Zebra®)	DM4 / DMI / DPP / ZPI2 / EPI2	Datamax® / Zebra® compatibility selection DM4 : Datamax® 400 DMI : Datamax® IClass™ DPP : Datamax® Prodigy Plus® ZPI2 : Zebra® ZPL2™ EPI2 : Zebra® EPL2™
Emulation Auto Detect	Full Auto	On / Off / Full Auto	Setting emulation (as above) auto detection.
Symbol Set	PM	50 symbols	Setting symbol set.
Custom Info Display	Model Number only	Model Number /Global Config Name /Onboard IP Address /Option board IP Address	Select the printer information displayed at the top of the LCD top screen using the check boxes * Even if the IP address check box is selected, if communication in accordance with the IP address is not possible, -. -. -. will be displayed on the top screen.
Display Language	English	English / 日本語 / 简体中文 / 한국어	Select the LCD display language.
Preview Mode	Off	On / Off	Print preview function settings

Sensor Setup

Sub Menu	Default	Configurable range	Remarks
Sensor Select	Rear Adj Sensor	Rear Adj Sensor / Front Fixed Sensor	Select the front/adjustable sensor
Media Sensor	See Through	See Through / Reflect /None	Selecting media sensor.
Sensor Monitor	-	-	Displays level of sensor that is currently selected.
Sensor Level	1.7 V	0.0 V to 3.3 V	Selects threshold of the sensor.
Paper End Level	3.00 V	0.01 V to 3.30 V	Sets the paper end level

Locking Setup

Sub Menu	Default	Configurable range	Remarks
Settings Lock	Off	On / Off	Prevents a command changing the set value.
Keyboard Lock	Off	On / Off	Prevents a change by a key operation.
CI Lock	Off	On / Off	Activates/deactivates the CI command. (Only when Zebra® emulation is selected)

Standalone Forms

Sub Menu	Default	Configurable range	Remarks
Forms Printing	Off	On / Off	Forms Printing settings
Forms Management	-	-	Template management for Standalone Forms

USB Memory

Sub Menu	Default	Configurable range	Remarks
Save Setting	-	-	Save the printer settings as a setting file
Load Setting	-	-	Change the printer settings using a setting file
Import Template	-	-	Register a template for Forms Printing on the printer
Update Firmware	-	-	Perform firmware updates

Menu: After Print

Sub Menu	Default	Configurable range	Remarks
Auto Configure	On	On / Off	Automatically configures optional devices. On: AutoConfigure enabled (Regardless of whether Function Select is set, if a peeler or cutter is installed, each mode is set automatically.) Off: AutoConfigure disabled (A peeler or cutter is installed, but to not operate the peeler or cutter, turn it Off and the operation is selected by Function Select.)
Function Select	Off	Off / Tear On / Peel On (only printers with peeling function) / Cut On (only when a cutter is installed)	Selects the operation when the AutoConfigure is set to Off. Designates the paper position based on each option. The operation of this device is enabled during selection. At the same time, the parameters of the f command of Prodigy Plus are emulated for each optional device.
Rewinder Auto Online *CL-S700 III R/CL-S703 III R	Off	On / Off	Sets the Rewinder Auto Online. In the case in which the setting is On, when the "Rewind Open" Error occurs, if the Rewinder Cover is closed, it will automatically return to "Ready" and printing will restart.

Sub Menu	Default	Configurable range	Remarks
Rewinder Online Delay *CL-S700 III R/CL-S703 III R	2 sec	1-10 sec	Sets the Rewinder Online Delay. Sets the time until the Rewinder restarts after the Rewinder Cover is closed when the above Rewinder Auto Online is On.
Rewinder Torque *CL-S700 III R/CL-S703 III R	4	1-7	Sets the Rewinder Torque.
Cutter Action *Only when cutter is mounted.	Backfeed	Backfeed / Through	Sets the cutter action. With the optional AutoConfigure On, printing is executed only when the cutter is installed or only when "Cut On" is selected by Function Select. "Backfeed" is always set after cutting. "Through" is set at the rear end of sheets 1 to n-1 when the number of copies = n, and the rear end of the final page of single sheet and the copy is backfeed.
Non-stop Cut *Only equipment with care label cutter	On w/o Backfeed	Off On w/ Backfeed On w/o Backfeed	Non-Stop Cut Settings Off When printing multiple sheets, the paper feed is stopped for each sheet when cutting. On w/ Backfeed When printing multiple pages, cutting is done without stopping feed. Backfeed is performed at the start of printing to bring printing from the top of the paper. On w/o Backfeed When printing multiple pages, cutting is done without stopping feed. Backfeed is not performed at the start of printing.
Peel Wait Delay *Only when peeling option is mounted.	0.1 sec	0.1 to 2.0 sec	Sets the Peel Wait Delay. Displays only machines with a peeler installed.

Sub Menu	Default	Configurable range	Remarks
Paper Position	0.00 inch / 0.0 mm	When the function selection is set to "Off" (Printing start position (platen-centered)) 0.00 to 2.00 inch / 0.0 to 50.8 mm When the function selection is set to "Tear/Peel On/Cut On" (Tear position/Peel On position/Cut On position) -1.00 to 1.00 inch / -25.4 to 25.4 mm	Adjusts the stop position. It is based on the inch/millimeter setting. There are initial values of the stop position for each device set by "Function Select", and later, relative values are set.

Menu: Interfaces -> Interface

Sub Menu	Default	Configurable range	Remarks
USB Device Class	Printer	Printer / VCOM	Selects the USB device class.
USB VCOM Protocol	Auto	Auto / DTR / X-ON	Selects the protocol (flow control) when operating USB VCOM.
USB 2.0 High Speed	On	On / Off	Enable/disable setting of USB 2.0 High Speed. When disabled, device runs at Full Speed.
IPv4 Address	0.0.0.0	0.0.0.0 to 255.255.255.255	Sets the IPv4 network address
IPv4 Subnet	0.0.0.0	0.0.0.0 to 255.255.255.255	Sets the IPv4 subnet mask
IPv4 Gateway	0.0.0.0	0.0.0.0 to 255.255.255.255	Sets the IPv4 gateway address
IPv4 DHCP	On	On / Off	Enables/disables IPv4 DHCP
IPv6	On	On / Off	Enables/disables IPv6
Host Name	PRINTSERVERxyzz * For xyzz, see the last three digits of the MAC address.	Arbitrary characters from 0 to 31 in ASCII code 0x20 to 0x7E	Host name as the print server
Port No.	9100	1024 to 65535	Port number used as the Raw Socket Port
Timeout Time	60	0 to 300	When there is a session with the timeout time for the connection to the host device in units of seconds, and there has been no data received from the host for the set period of time, the session will be terminated when the set value for the number of seconds has passed. Setting a value of 0 disables timeouts.

* For each setting related to the interface, the setting becomes enabled after turning on the power again or after restarting.

Option Interface

Sub Menu	Default	Configurable range	Remarks
RS-232C Baud rate	9600	115200 / 57600 / 38400 / 19200 / 9600 / 4800 / 2400	Setting the baud rate of the serial interface.
RS-232C Parity	None	None / Odd / Even	Setting the communication parity for the serial interface.
RS-232C Length	8-bits	8-bits / 7-bits	Setting the character length for the serial interface.
RS-232C Stop bit	1-bit	1-bit / 2-bits	Setting the stop bit for the serial interface.
RS-232C X- ON	Yes	Yes / No	Selectively setting the X-ON flow control of the serial interface.
IEEE 1284	On	On / Off	Setting both direction of the Centro Interface. (When a parallel board or a high-end LAN board is installed)
Web Monitor	Auto	Auto / On / Off	Selecting the web monitor function. (When a parallel board or a high-end LAN board is installed)
Network Ad- dress	-	0.0.0.0 to 255.255.255.255	Sets the network address (When a high-end LAN board is installed and a web monitor is operating)
Subnet Mask	-	0.0.0.0 to 255.255.255.255	Sets the subnet mask (When a high-end LAN board is installed and a web monitor is operating)
Gateway address	-	0.0.0.0 to 255.255.255.255	Sets the gateway address (When a high-end LAN board is installed and a web monitor is operating)
BOOTP	-	On / Off	BOOTP setting (When a high-end LAN board is installed and a web monitor is operating)
DHCP	-	On / Off	DHCP setting (When a high-end LAN board is installed and a web monitor is operating)
WLAN Mode	-	Auto / Ad-Hoc / Infra- structure / Soft AP	Sets the wireless LAN mode (When a high-end LAN board is installed and a web monitor is operating)
WLAN Chan- nel	-	01 to 14	Sets the wireless LAN channel (When a high-end LAN board is installed and a web monitor is operating)
WLAN SSID	-	Max. 32 characters	Sets the wireless LAN SSID (When a high-end LAN board is installed and a web monitor is operating)

Menu: Test & Info → Test Mode

Sub Menu	Default	Configurable range	Remarks
Print Pattern	Current Con- fig	Current Config / Global Config / Sam- ple	Executes the test pattern.
Head Check	No	Yes / No	Executes head check.

Sub Menu	Default	Configurable range	Remarks
Factory Default	No	Yes / No	Initializes the set values of the configuration set to the state when the unit was shipped from the factory.
Hex Dump	No	Yes / No	Sets the hex dump mode.
Serial Monitor	-	-	Displays the state of the serial interface.
Auto Calibration	See Through	See Through / Reflect	Executes the calibration of the sensor.
Sensor Monitor	See Through	See Through / Reflect	Displays the level of the sensor.

Machine-Info

Sub Menu	Configurable range	Remarks
Model Number	CL-S70X III	Displays the model's name.
Boot Version	.*	Displays the boot version.
ROM Version	*****	Displays the ROM version.
ROM Date (DD/MM/YY)	**/**/**	Displays the date the ROM was prepared.
ROM CheckSum	****	Displays the check sum of the ROM.
FPGA Version	.*	Displays the FPGA version.
Head Check	OK / NG	Displays the results of the head check.
Print Counter *	****.*** km	Displays the print counter.
Service Counter *	****.*** km	Displays the service counter.
Cut Counter	*****	Displays the cut count.
Sensor Monitor	.* V	Displays the sensor level.
Option I/F	None / RS-232C* / LAN / IEEE1284	Displays whether optional interfaces are available or not * If DIP switch 1 is ON in an RS-232C interface, RS-232C (DIP SW) will be displayed.
RS-232C Baud rate		If DIP switch 1 is ON in an RS-232C interface, the communication conditions set for the DIP switch will be displayed.
RS-232C Parity		
RS-232C Length		
RS-232C Stop bit		
RS-232C X-ON		
MAC Address	*****	Displays the MAC address

* If the double heat function is enabled, the value doubles.

Global Configuration

Sub Menu	Default	Configurable range	Remarks
-	Config Set 1	Config Set 1 / Config Set 2 / Config Set 3	Sets the Config Set.

Wizard

Sub Menu	Default	Configurable range	Remarks
-	-	-	The basic settings of the printer can be performed in accordance with procedures displayed on the screen.

Global Configuration Sets

The printer can store three sets of configuration settings that can be recalled quickly and easily.

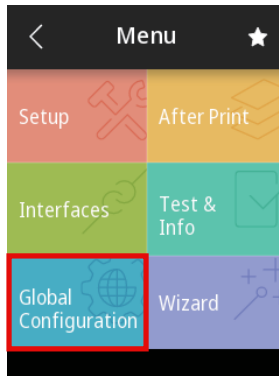

Different setting values set for [Config Set 1] to [Config Set 3] can be saved.

For example, [Config Set 1] can be set to "Print Speed 5 IPS," "Print Method Thermal Transfer," and "Print Darkness 18," and [Config Set 2] can be set to "Print Speed 8 IPS," "Print Method Direct Thermal," and "Print Darkness 12."

Using the three types of settings in this way, different media (labels) can be easily handled in daily use.

Printing can be carried out from "Test & Info" -> "Test Mode" -> "Print Pattern" -> "All Menu Settings."

Global Menu Settings

	Active Configuration Setting		
	Config 1	Config 2	Config 3
[Page Setup Menu]			
Print Speed	7 IPS	7 IPS	7 IPS
Print Darkness	12	12	12
Darkness Adjust	00	00	00
Print Preference	Darkness	Darkness	Darkness
Print Method	DT	TT	TT
Continuous Media Length	004.00inch	004.00inch	004.00inch
Vertical Position	+0.00inch	+0.00inch	+0.00inch
Horizontal Shift	+0.00inch	+0.00inch	+0.00inch
Vertical Image Shift	00.00inch	00.00inch	00.00inch
Small Media Adjustment	Off	Off	Off
Small Media Length	1.00inch	1.00inch	1.00inch
[Sensor Setup Menu]			
Media Sensor	None	See Through	See Through
Sensor Select	Rear Adj Sen	Rear Adj Sen	Rear Adj Sen
Sensor Level	1.5V	1.7V	1.7V
Paper End Level	1.50V	3.00V	3.00V
[System Setup Menu]			
Error Reporting	On Printing	On Printing	On Printing
Buzzer Select	On	On	On
Metric/Inch Select	Inch	Inch	Inch
Max Media Length	010.00inch	010.00inch	010.00inch
LD Standby	Off	Off	Off
Standby Timer	5min	5min	5min
Control Code	STD	STD	STD
Emulation Select	DM4	DM4	DM4
Emulation Auto Detect	Full Auto	Full Auto	Full Auto
Symbol Set	PM	PM	PM
LD Brightness	100%	100%	100%
Preview Mode	Off	Off	Off
[Locking Setup Menu]			
Settings Lock	Off	Off	Off
Keyboard Lock	Off	Off	Off
[Standalone Forms Menu]			
Forms Printing	Off	Off	Off
[After Print Menu]			
Auto Configure	On	On	On
Function Select	Tear	Tear	Tear
Paper Position	+0.00 inch	+0.00 inch	+0.00 inch
[Interface Menu]			
USB Device Class	Printer	Printer	Printer
USB VCOM Protocol	Auto	Auto	Auto
USB 2.0 High Speed	On	On	On
IPv4 Address	00. 00. 00. 00	00. 00. 00. 00	00. 00. 00. 00
IPv4 Subnet Mask	00. 00. 00. 00	00. 00. 00. 00	00. 00. 00. 00
IPv4 Gateway	00. 00. 00. 00	00. 00. 00. 00	00. 00. 00. 00
IPv4 DHCP	On	On	On
IPv6	On	On	On

Wizard

The basic settings of the printer can be performed in accordance with procedures displayed on the screen.

1. Select “Wizard” from the menu screen.

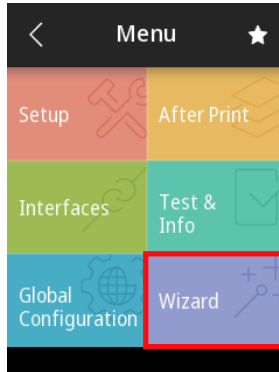

2. Perform the printer settings in the following sequence in accordance with procedures on the screen.

1. Ribbon/Media settings
2. Sensor adjustment
3. Test print & saving settings

Shortcut registration

Press the “Shortcuts” button at the bottom of the top screen while printing is enabled to display the shortcuts menu screen.

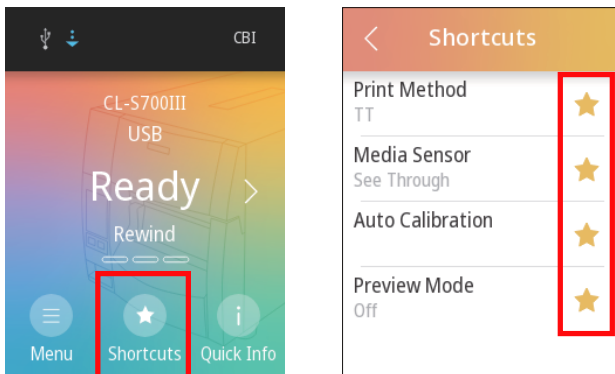

Shortcuts can be registered by pressing the star icons on the sub-menu screen.

In addition, shortcut registrations can be deleted by pressing the star icons on the sub-menu or in the shortcut menu list.

Quick information list display

Press the “Quick Info” button at the bottom of the top screen while printing is enabled to display the printer “Quick Info” screen.

The basic information of the printer can be easily checked by accessing the “Machine-Info” from the menu.

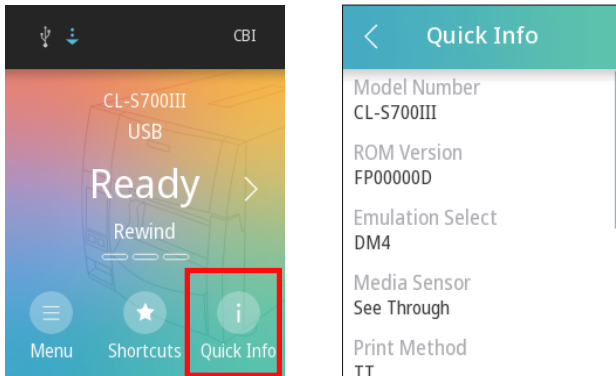

Reprinting

By performing the following operations, the content that has been previously printed most recently can be reprinted.

1. Press the right arrow button on the top screen, and press the “Repeat Last One” or “Repeat Last Set” button.

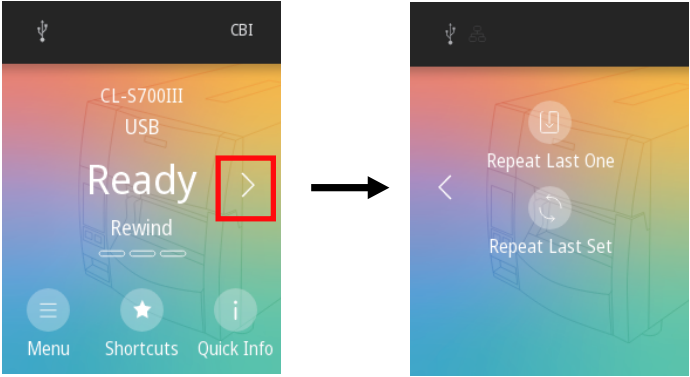

* When Zebra® emulation is selected, the “Repeat Last Set” button is not displayed.

2. When the “Reprint” button on the screen displayed is pressed, reprinting starts. (The following figure shows the case for “Repeat Last One”)

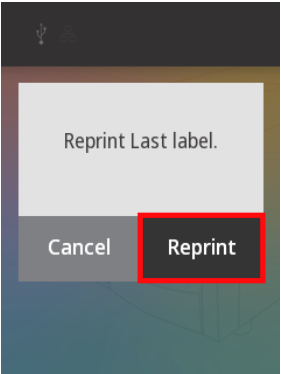

Clearing jobs

Jobs stored in the printer can be canceled when the printer is paused. Jobs can be canceled by performing the following operations in the paused state.

1. Press the “Job Clear” button or the “Job All Clear” button at the bottom of the screen.

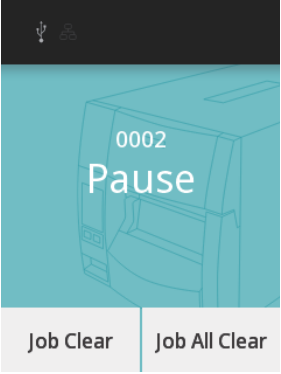

2. Press the “Job Clear” button on the screen displayed to cancel the job.

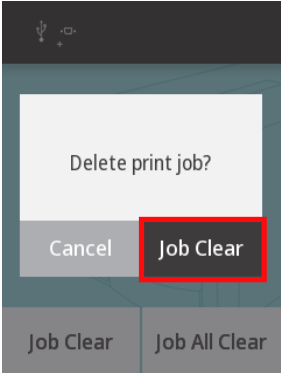

Forms Printing

Forms Printing is a function that enables printing labels on a printer on its own, without a PC, by preparing a template for printing labels on Label Layout Editor, a special PC application. In addition, data from a USB barcode scanner or USB memory connected to the printer can be used as barcode data or character string data in the printing template. This function is only enabled when the Emulation Select setting is DMI.

1. Preparation

Set the Emulation Select setting to DMI in advance. Prepare the print data template or register the template on the printer using the Label Layout Editor PC application. In addition, templates can be registered from a USB memory connected to the printer, or templates can be deleted or fixed (a single template is automatically selected when the printer is started) from the printer menu settings.

* For details, refer to the Label Layout Editor instruction manual.

2. Execution

If "Setup" -> "Standalone Forms" -> "Forms Printing" is turned on in the menu settings, and the printer is restarted, if there is a template that was registered from Layout Editor, the following selection screen will be displayed.

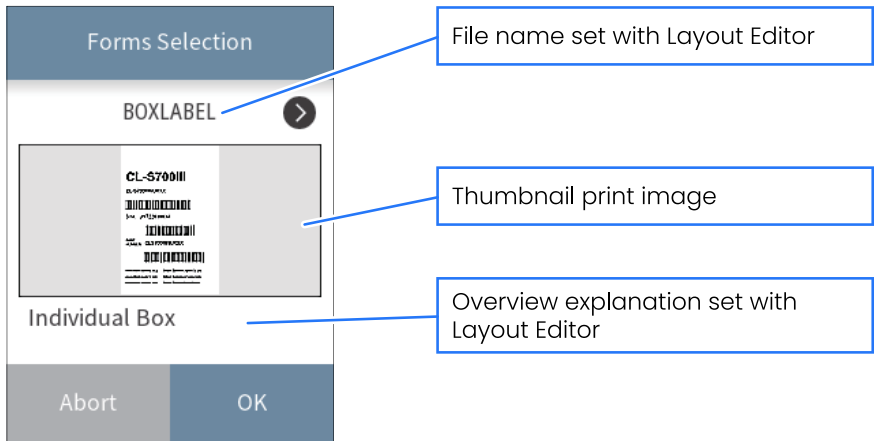

- If there are several templates, display the template you want to print using the < > buttons.
- Press the "OK" button, and Forms Printing of the displayed template will be executed.
- Press the "Abort" button, to stop template selection, and the screen will return to the menu top screen.

3. Aborting Forms Printing

In the template selection screen, press the "Abort" button, return to the menu top screen, and turn off the "Standalone Forms" -> "Forms Printing" setting. The next time the printer is started up, the template selection screen will not be displayed.

USB host function

By connecting a USB memory or a barcode scanner to the USB host connector at the front of the main unit, the following functions can be executed.

- Updating of firmware using the USB memory

- Saving the printer settings using the USB memory (a maximum of five settings can be imported)
- Restoring printer settings using the USB memory (a maximum of five settings can be exported)
- Importing templates for Forms Printing using the USB memory
- Reading barcodes using the barcode scanner (the barcode scanner can be used in Forms Printing)

Notes

- The USB memory must have a capacity of 32 GB or less and be in FAT32 format.
- Do not use USB memories with a security function or USB memory card readers, or connect via extension cables or a USB hub.

Updating of firmware using the USB memory

1. Preparation

Create a folder named “JN” in the USB memory, and save the update file in the folder with the name “UPDATE” and the extension nar.

* Contact your retailer for details on the update file.

2. When a USB memory is connected to the printer, the USB memory menu is added to the setup menu.

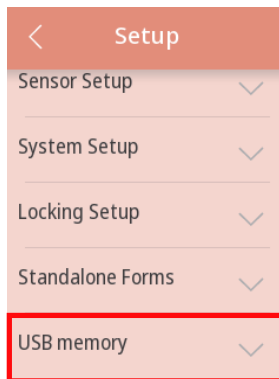

3. Press the “USB memory” button, and press “Update Firmware” from the expanded list.

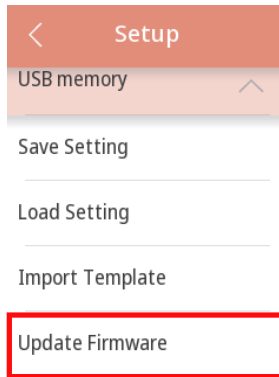

4. Press the “OK” button at the bottom of the screen to acquire and display the update information.

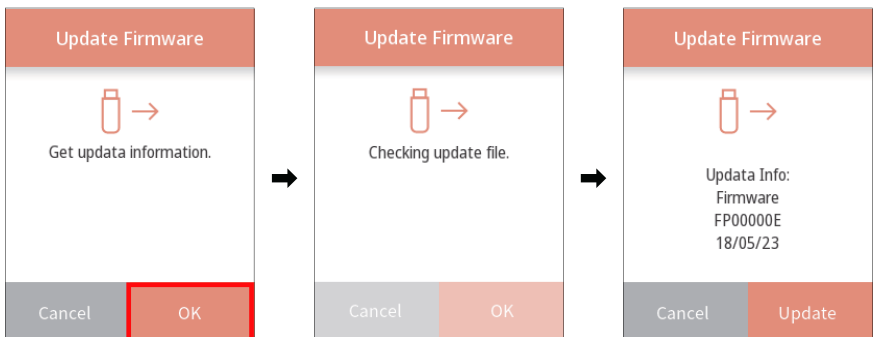

5. Press “Update” at the bottom of the screen to start the update.

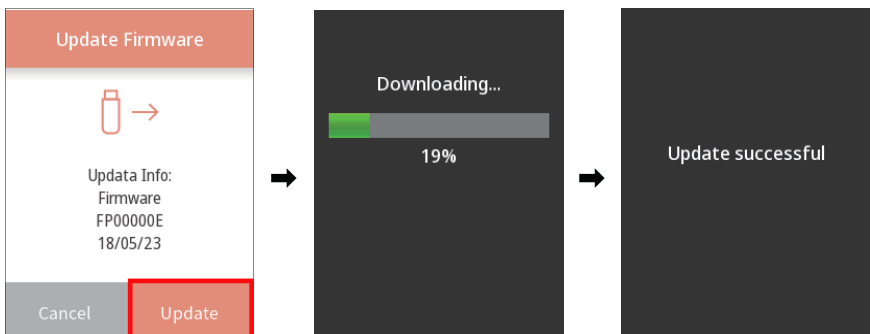

Saving printer settings to a USB memory

1. Preparation

When a USB memory is connected to the printer, the USB memory is displayed in the setup menu. Next, press Save Setting.

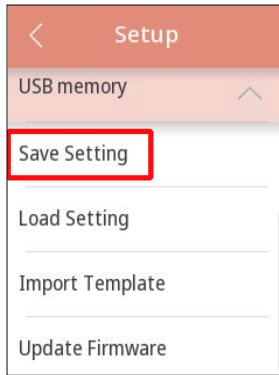

2. Select the destination for saving the settings

Select one save destination from the five destinations, and press the "OK" button.

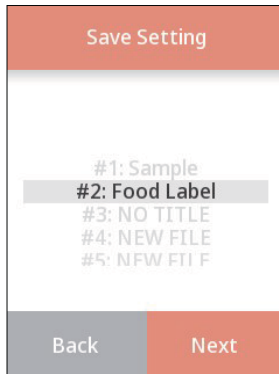

3. Enter the setting explanation and save the settings

An explanation can be added to a setting, so after entering the explanation text using the keyboard, press the "OK" button and the printer settings will be saved to the USB memory as a file.

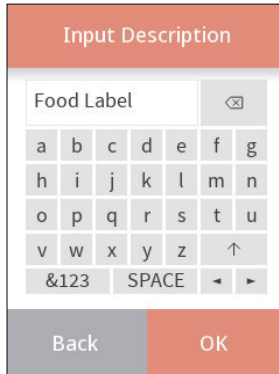

The printer settings saved to the USB memory are as follows. In addition, the following settings included in Global Configuration and the selection number of the Global Configuration settings are included in the settings saved.

List of printer settings saved to USB memory

Page Setup	Print Speed
	Print Darkness
	Darkness Adjust
	Print Preference
	Print Method
	Double Heat
	Continuous Media Length
	Vertical Position
	Horizontal Shift
	Vertical Image Shift
	Small Media Adjustment
	Small Media Length

System Setup	Error Reporting Buzzer Select Metric/Inch Select Max Media Length LCD Brightness LCD Standby Standby Timer Control Code Media Power Up Emulation Select Emulation Auto Detect Symbol Set Preview Mode
Sensor Setup	Media Sensor Sensor Select
Locking Setup	Settings Lock Keyboard Lock CI Lock
Standalone Forms	Forms Printing Forms Management
After Print	Auto Configure Function Select Rewinder Auto Online Rewinder Online Deley Rewinder Torque Cutter Action Non-stop Cut Peel Wait Delay Paper Position
Interface	USB Device Class USB VCOM Protocol USB 2.0 High Speed
Option Interface	RS-232C Baud rate RS-232C Parity RS-232C Length RS-232C Stop bit RS-232C X-ON

Notes

Detailed information is saved in the USB memory "CLS" folder in a file with extension .CFG. The file is in a unique format for the printer, so do not edit it, etc.

Restoring printer settings from a USB memory

1. Preparation

When a USB memory is connected to the printer, the USB memory is displayed in the setup menu. Next, press “Load Setting.”

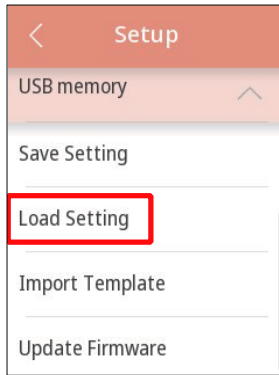

2. Select the settings to be restored

Select one setting from among the five settings stored on the USB memory, press the “OK” button, and the printer settings will be restored from the selected file.

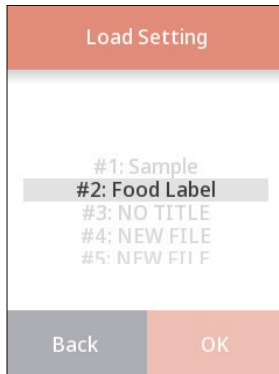

For the printer setting items to be restored, refer to the “List of printer settings saved to USB Memory” in “Saving printer settings to a USB memory.”

Importing templates for Forms Printing using the USB memory

1. Preparation

Create a “CLS” folder in the USB memory, and save the template file in the folder.

2. When a USB memory is connected to the printer, the USB memory is displayed in the setup menu. Next, press "Import Template."

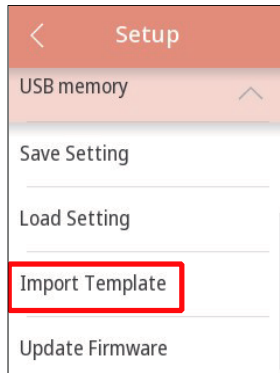

3. Press the “OK” button at the bottom of the screen to import the template from the USB memory.

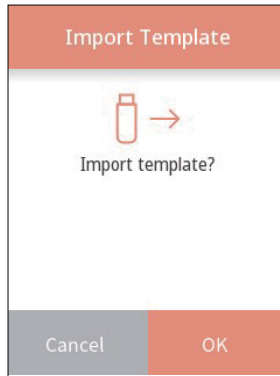

If importing is successful, the following screen is displayed.

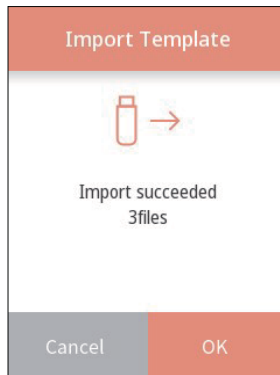

Print preview function

Before printing, the print image can be simply displayed on the LCD screen for checking.

When the print data is sent to the printer, the following preview screen is displayed.

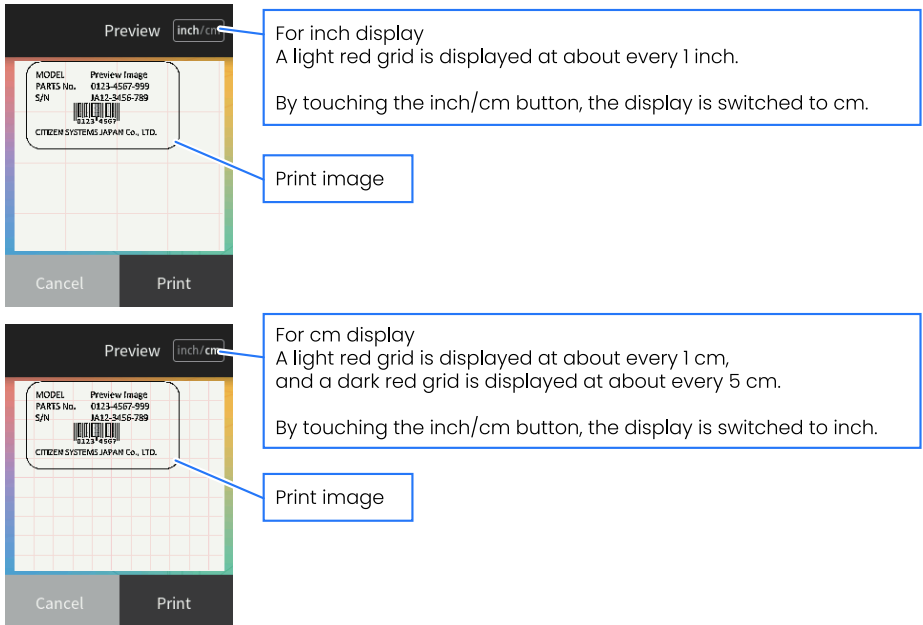

- The print image displayed is the first page of the job.
- Press the “Print” button to print the displayed job.
- Press the “Cancel” button to abort the displayed job without printing.
- The default state of the grid display is in accordance with the mm/inch setting or command in the menu settings.
- inch/mm button

Toggles between grid display every 1 inch and grid display every 1 cm.

* A job is data for continuous printing. When printing with the “Print” button, even if printing stops midway, if printing of the next job occurs within 0.5 seconds, it is determined to be the same job and printing continues without a preview. If the print data is aborted with the “Cancel” button, the print data received within 0.5 seconds is aborted.

* If reprinting is performed from the top menu immediately after the job is aborted during preview, the aborted data is printed.

* A preview is not displayed for self-printing, configuration printing, and HEX dump mode. (Printed the same as with preview mode turned Off.)

* For print images that cannot entirely fit in the preview, such as long media, only the media on the printer side (the latter half that will be printed) is displayed.

The SAMPLE characters on the front side are not printed

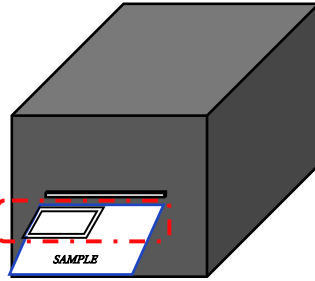
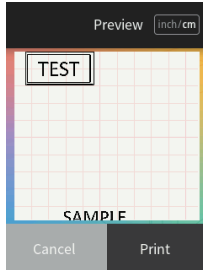

3.9 Emulation Auto-Detection

If a control language different from the emulation when operating with the Emulation Auto Detect setting in System Setup set to "On" or "Full Auto" is received, the emulation is automatically switched. Note that the Eltron language will not be detected.



Refer to List of Settings

When the Emulation Auto Detect setting is set to "Full Auto"

During startup, the saved emulation is started by "Setup" -> "System Setup" -> "Emulation Select." Then, operation is continued with the emulation of the initially-received control language. New emulations are saved to the Emulation Select setting. At this time, automatic restart is not carried out.

If the printer is manually restarted later on, it will start up with the newly saved emulation setting. When a different control language is received without restarting, the emulation of the last received control language is saved in the command settings, and automatic restart is carried out. Note that the data received before restarting is ignored.

When the Emulation Auto Detect setting is set to "On"

The following message is displayed on the LCD when the Zebra® emulation (ZPI2) command is detected during Datamax® emulation.

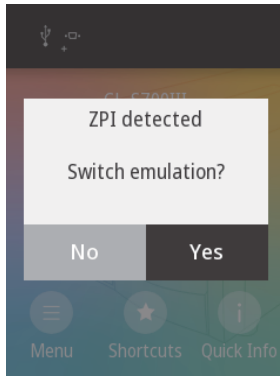

If “Yes” is selected, a restart is executed, and the printer automatically switches to Zebra® emulation (ZPI2®).

If “No” is selected, emulation is not switched, and the online state is restored. When Zebra® emulation is set, if a Datamax® emulation (DM4/DMI/DPP) command is received, the following is displayed on the LCD.

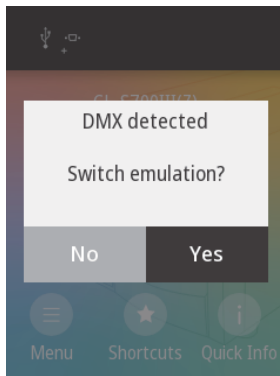

If “Yes” is selected, a restart is executed, and the printer automatically switches to Datamax® emulation (DM4/DMI/DPP).

If “No” is selected, emulation is not switched, and the online state is restored.

Caution

When the sub-menu “Emulation Auto Detect” in the “System Setup” main menu is set to Off, the emulation auto detection function does not operate.

If the emulation auto detection function is set to On, when the printer power is turned back on, it is enabled.

3.10 Calibrating the Touch Panel

If touch operation of the menu does not operate correctly, calibrate the touch panel. Calibrate the touch panel by pushing the “PAUSE” key while touching the touch panel with the printer power turned OFF, then turning the printer power ON, and waiting for a while. After a while, the screen shown on the left below is displayed. Touch “Start.” Then, the targets shown on the screen on the right below are displayed in sequence, so touch the center of the targets successively.

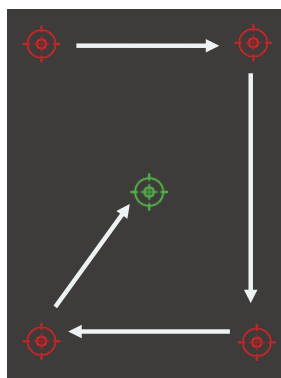
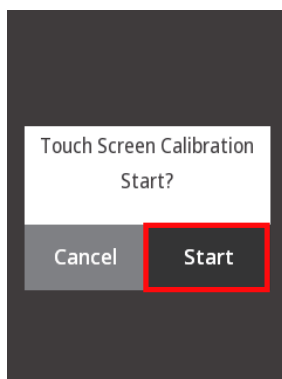

After touching all the targets, the following screen is displayed if the calibration is completed correctly. This completes calibration of the touch panel.

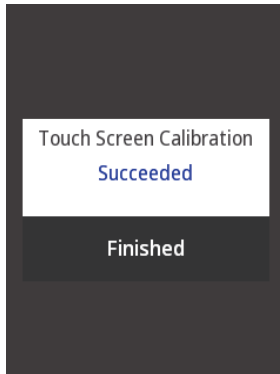

3.11 Setting the menu for the Rewinder (CL-S700 III R / CL-S703 III R only)

Set the Menu Setup Mode as follows to use the rewinder function.



Refer to Menu settings

When rewinding the liner using the peeler



Refer to List of Settings

- Set the "Function Select (sub-menu)" setting to "Peel On."
- When "Auto Config (sub-menu)" is set to "On," "Peel On" is automatically selected.

4. Printer Adjustments

4.1 Sensor Adjustments

The sensing level of the label detection sensor (transparent sensor), black mark detection sensor (reflective sensor), and continuous media detection sensor (reflective sensor) are adjusted separately and independently.

Selecting the sensor

To select the front sensor or the adjustable sensor, select the sensor to be used from "Setup" on the menu screen -> "Sensor Setup" -> "Sensor Select."

Adjusting the label detection sensor (see-through sensor)

1. Select label detection sensor (see-through sensor). Select "See Through" from "Setup" on the menu screen -> "Sensor Setup" -> "Media Sensor."

2. Peel a label and set the media so that only the backing paper (glassine paper) reaches the platen roller and media sensor. (In the case of media (labels) with black lines, take care to ensure that the black line does not reach the media sensor.) Then, lock the head unit.

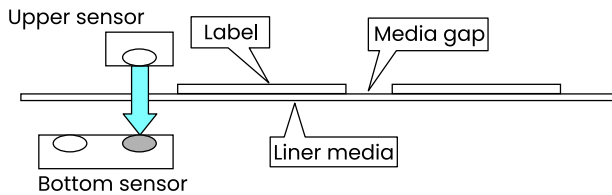
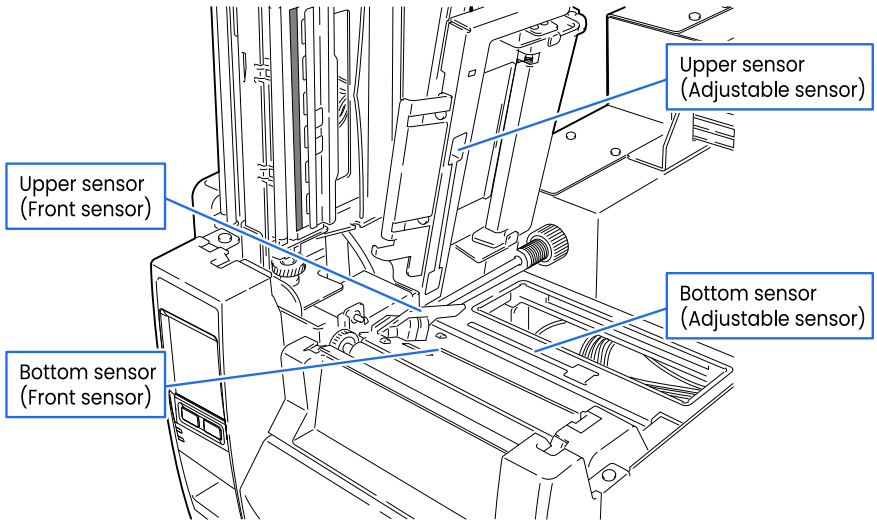

3. Adjust the sensors. Select "See Through" from "Test & Info" on the menu screen -> "Test Mode" -> "Auto Calibration," and press the "OK" button at the bottom of the screen. Press the "Start" button on the screen displayed, and the sensor will be automatically adjusted.

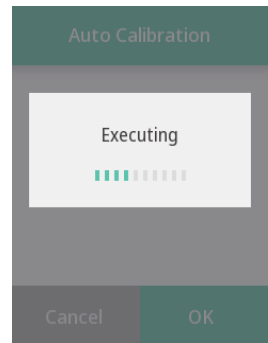
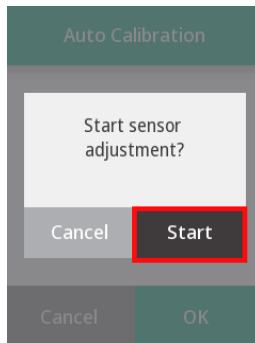
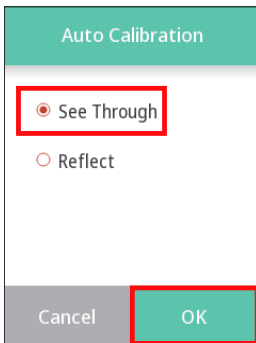

4. If the automatic adjustment is completed normally, "OK" will be displayed on the screen. If it is completed abnormally (adjustment not possible), the error LED flashes, and "Failed" will be displayed on the screen.

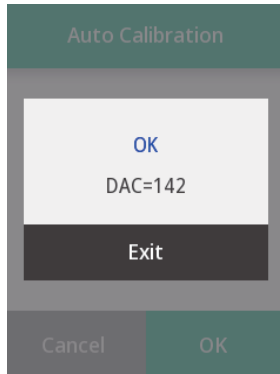

Adjusting the black mark detection sensor (Reflective sensor)

1. Select the black mark detection sensor (reflective sensor). Select "Reflect" from "Setup" on the menu screen -> "Sensor Setup" -> "Media Sensor."

2. Set the media so that the media covers the platen roller and media sensor.
 Set that media so that black lines or gaps between labels do not cover the sensor.

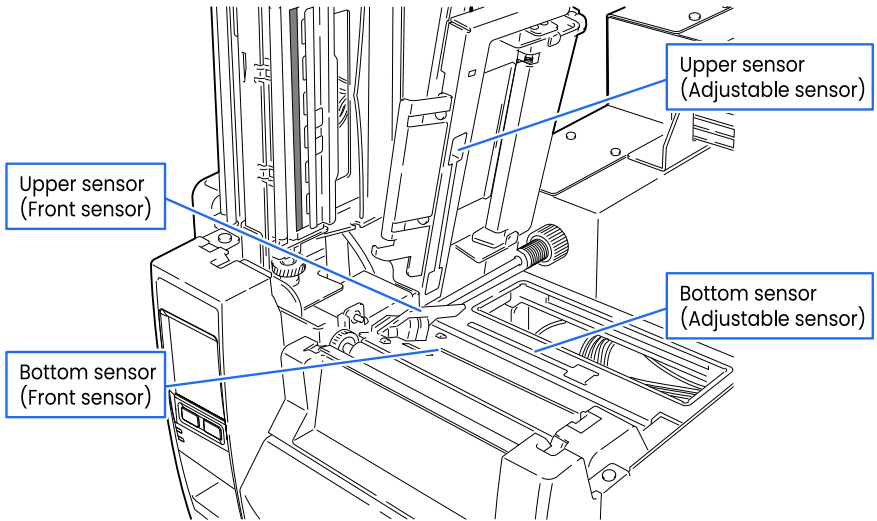

- Using continuous media and label media without gaps between labels
 Set the media so that a section without a black line (or label face stock for label media) does cover the platen roller and media sensor.

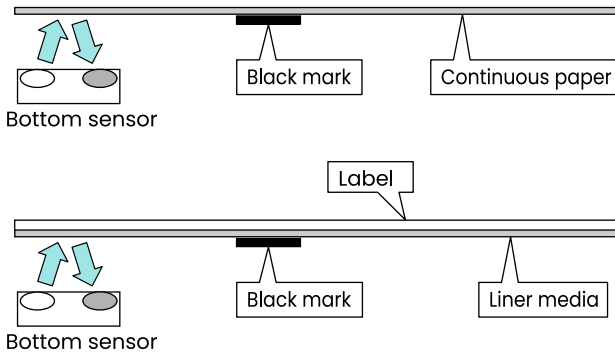

- Using label media with gaps
 Peel a label and set the media so that only the backing paper (glassine paper) reaches the platen roller and media sensor.

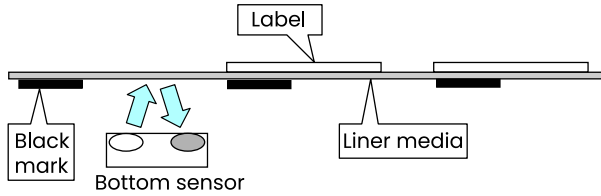

3. Adjust the sensors. Select “Reflect” from “Test & Info” on the menu screen -> “Test Mode” -> “Auto Calibration,” and press the “OK” button at the bottom of the screen. Press the “Start” button on the screen displayed, and the sensor will be automatically adjusted.

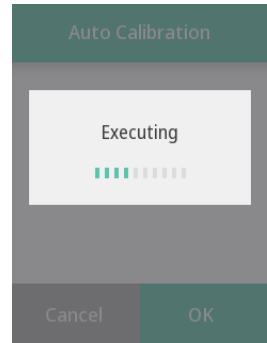
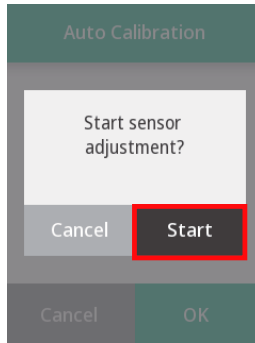
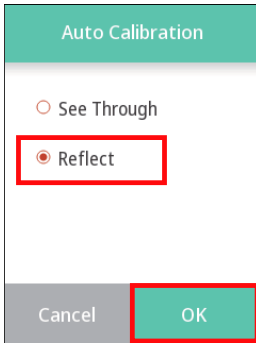

4. If the automatic adjustment is completed normally, “OK” will be displayed on the screen. If it is completed abnormally (adjustment not possible), the error LED flashes, and “Failed” will be displayed on the screen.

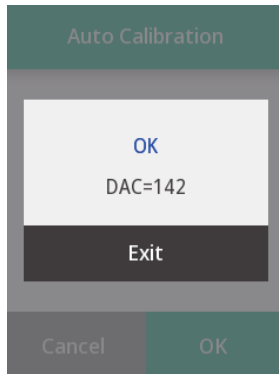

Adjusting the continuous media detection sensor (Reflective sensor)

1. Select the continuous media detection sensor (reflective sensor). Select “None” from “Setup” on the menu screen -> “Sensor Setup” -> “Media Sensor.”

2. Set the media so that the media covers the platen roller and media sensor. If the media has black lines, do not set the media so that a black line is between the sensors.

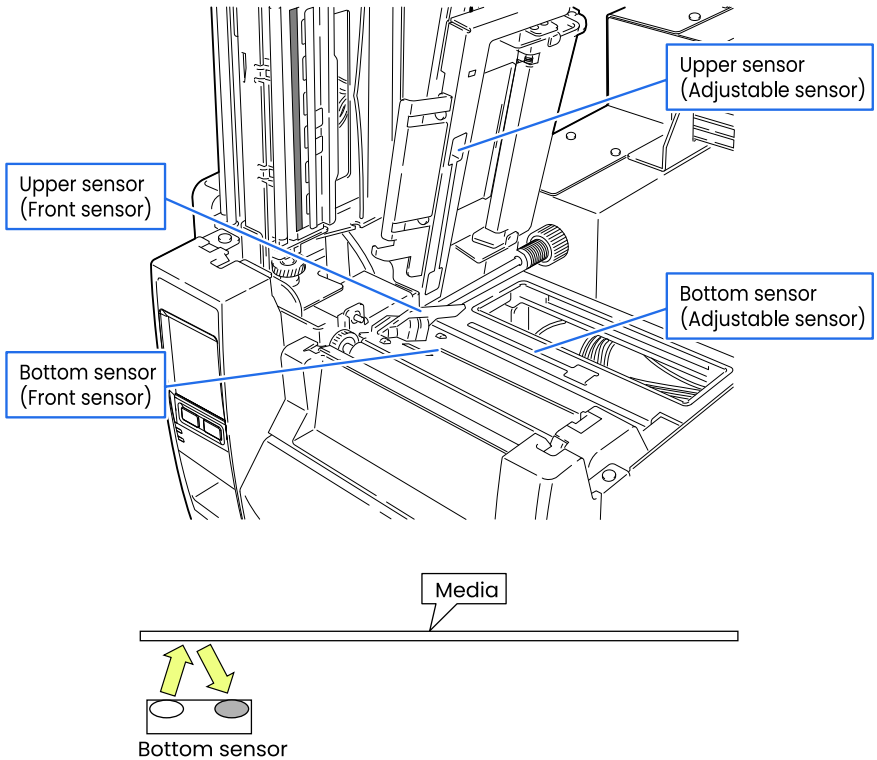

3. Adjust the sensors. Select "Reflect" from "Test & Info" on the menu screen -> "Test Mode" -> "Auto Calibration," and press the "OK" button at the bottom of the screen. Press the "Start" button on the screen displayed, and the sensor will be automatically adjusted.

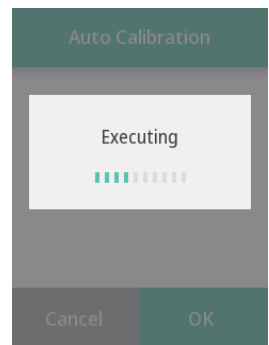
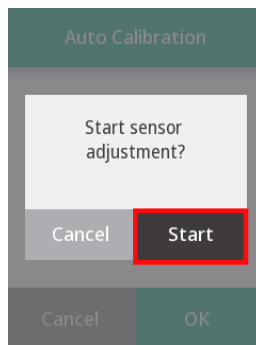
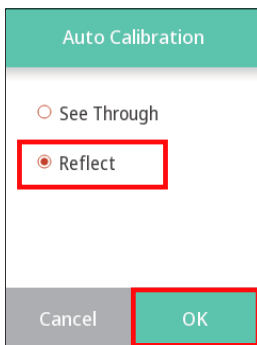

4. If the automatic adjustment is completed normally, "OK" will be displayed on the screen. If it is completed abnormally (adjustment not possible), the error LED flashes, and "Failed" will be displayed on the screen.

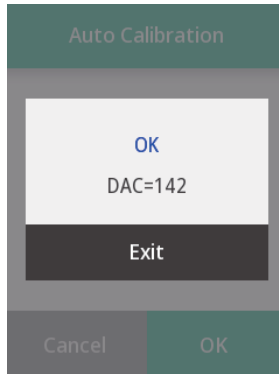

4.2 Media Thickness Adjustment

The printer is already factory-set to the requirements of proper print quality while using the recommended labels. If the print quality is inferior because of the different type of media, adjust the printhead position in the following manner:



Refer to Loading roll media

When using standard labels, or thermal media

1. Looking in at the media thickness check window, reset the printhead offset so that it comes to the center line (middle of the three lines) by turning the media thickness adjustment screw with a screwdriver.
2. Then turn the media thickness adjustment screw two to four times counterclockwise with a screwdriver. (Factory setting: two turns.)
3. Make fine adjustments by checking the self-test print.



Refer to Self Print

When using thick media (tags or other media)

1. Looking in at the media thickness check window, reset the printhead position so that it comes to the center line (middle of the three lines) by turning the media thickness adjustment screw with a screwdriver.
2. Then turn the media thickness adjustment screw two to four times clockwise with a screwdriver.
3. Make fine adjustments by checking the self-test print.



Refer to Self Print

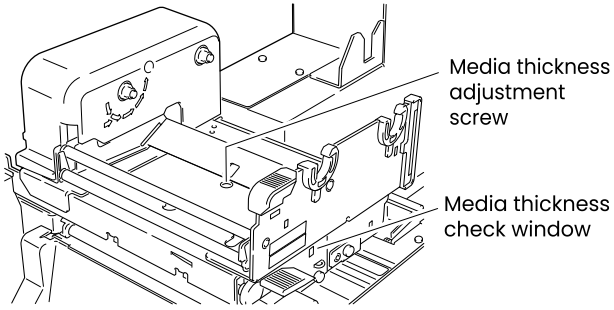

The relationship between the printhead heating element and the media thickness check window is shown below:

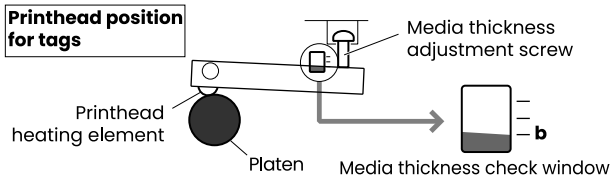
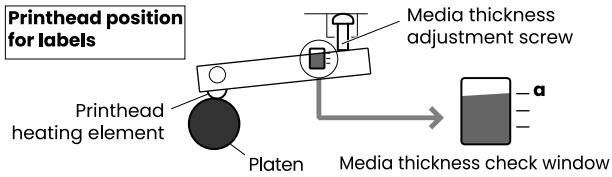

4.3 Media Width Adjustment

The printer is already factory-set to the value of media width: 112 mm (4.4 in). When you use narrow media, adjust the printhead pressure in the following:



Refer to Loading roll media

1. Looking in at the check window on the upper frame, align the mark (the left end of white plastic) with the width of media by turning the media width adjustment knob. (The printhead must be closed.)
2. Make fine adjustments by checking the self-test print.



Refer to Self Print

When the print on right side is too light:

Move the mark (white) to the right side by turning the media width adjustment knob clockwise.

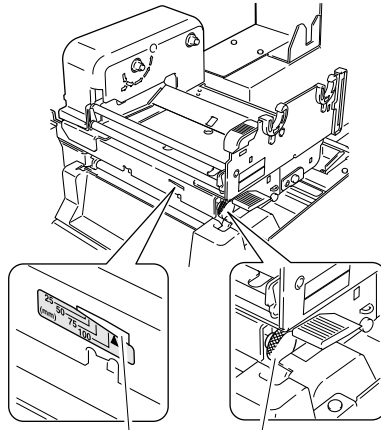

When the print on the left side is too light:

Move the mark to the left side by turning the media width adjustment knob counterclockwise.

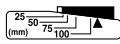
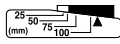
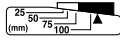
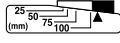

Media width check window

Media width adjustment knob

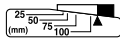
Check window	Width of media	
		25.4 mm
	50.8 mm	2 inch
	76.2 mm	3 inch
	101.6 mm	4 inch
	When ribbon wrinkles or media screws with media width of 4 in or more	
	Factory setting	

4.4 Adjusting the Ribbon

Ribbon tension in this printer is already adjusted for the recommended ink ribbon and media and is very tolerant to different types of media. However, it may slip due to imperfect combinations of ribbon and media and it is possible that you will see a "Ribbon End" message even though the ribbon is not finished. This is more likely to happen with narrow width ribbons, especially those less than 50mm (2 inches).

To resolve this problem and obtain the optimum printing condition, make adjustments in the following manner (this should be done after the print-head pressure adjustments on the previous page are made):

* Perform this adjustment after the previous section "4.3 Media Width Adjustment."



Refer to 3.7 Setting the Ribbon



Refer to 4.3 Media Width Adjustment

Adjusting Places

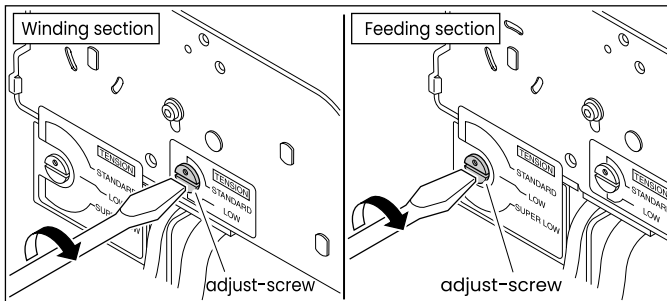

When turning adjust-screw, use a flat-tip screwdriver.

Adjusting Method

1. General ribbon and media

Factory setting: both marks on winding and feeding sections are set to STANDARD so as to obtain the optimum printing condition for the recommended ink ribbon and media.

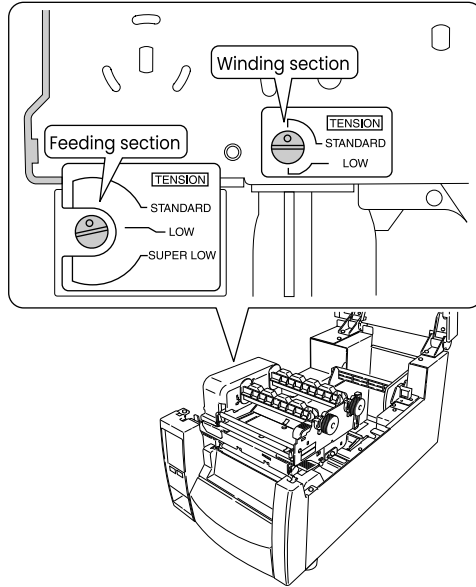

2. Easy-to-slip ribbon and media

If a message "Ribbon Out" is shown, set the mark on the feeding section to LOW by turning the adjust-screw.

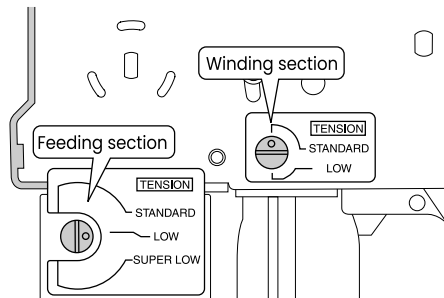

3. Especially-easy-to-slip ribbon and media

If a message "Ribbon Out" is still shown, although Step 2 has been performed, set the mark on the feeding section to SUPER LOW by turning the adjust-screw.

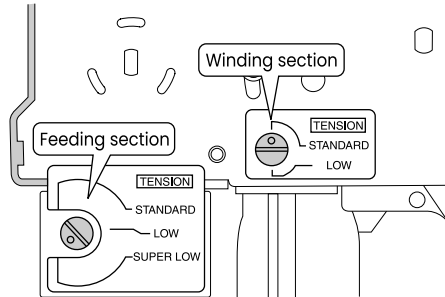

4. When ribbon is broken during printing

Ribbon may be broken if it is narrow in width and printhead heat temperature is high. In that case, set the mark on the feeding section to SUPER LOW and set the mark on the winding section to LOW by turning adjust-screw respectively.

If the problem is still not resolved, please contact our service personnel.

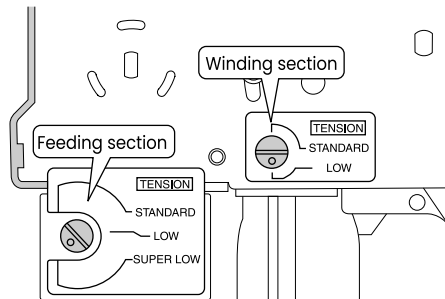

4.5 Adjustable Sensor Position Adjustment

Operating procedure

Measure your required detection position beforehand, using the scale on the upper guide rail. Move the adjustable sensor to the required detection position by tuning the adjustable knob; it is useful to align the yellow mark on the top of the adjustable sensor with the scale showing the required detection position.



Refer to List of Settings

Notes

Enabled only when an adjustable sensor is selected

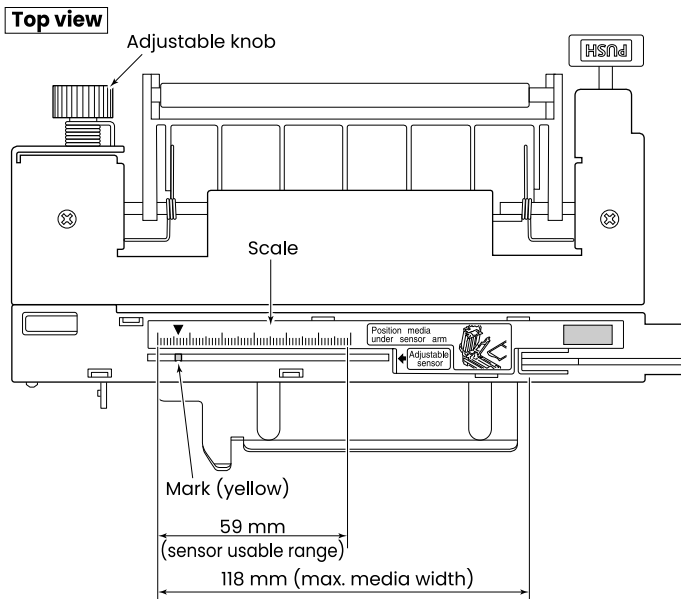

4.6 Cleaning

Wipe off any foreign objects such as media dust, dirt and adhesive substances built up around the printhead and platen with the head cleaning pen (head cleaner) provided, and use a soft cloth soaked in ethyl alcohol for the platen etc.

It is particularly important to clean the thermal printhead after printing on thermal media for long periods, which will guarantee the print quality and extend the life of the thermal printhead.

Caution

- Always use the head cleaner when cleaning the thermal printhead.
- The thermal head is hot immediately after printing. Do not touch the thermal head at this time
- Do not touch the thermal head with bare hands or do not allow metals to come into contact with the thermal head.

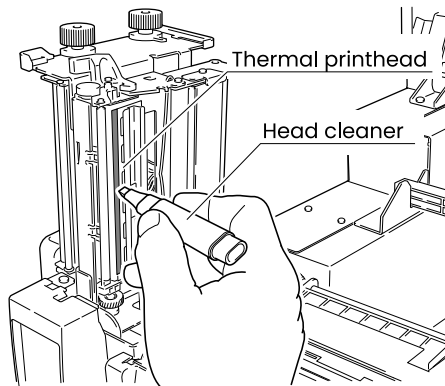

To clean the entire surface of the platen, rotate the platen little by little with your thumb using a cheese cloth. Do not touch the platen with your bare hands.

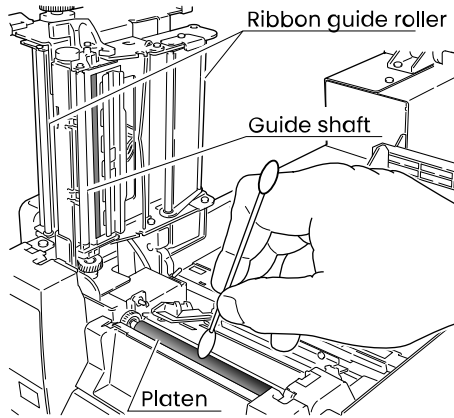

If the glue of the label media adheres to the roller, the peeled liner will stick and can cause a jam. Remove the glue adhered to the roller by using a cloth or something similar soaked in alcohol.

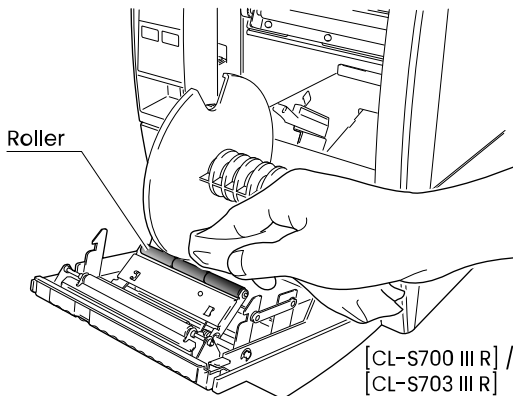

 **Caution**

Do not use any solvent other than ethyl alcohol. Solvents such as benzene, acetone and thinner will dissolve plastic parts and destroy the thermal printhead, platen and much of the printer!

Try to avoid using "excessive amounts" of ethyl alcohol to clean the platen. Excessive use will harden the platen surface prematurely.

5. Troubleshooting

When an error/alarm occurs, refer to the illustration displayed on the printer LCD, or refer to the URL of the QR code displayed.

For other problems, refer to the following. If the problem is not corrected even though action has been taken, contact your retailer's service personnel.

Symptom	Check	Corrective action
The LED do not light up when printer power is connected.	1 Is the plug of the power cord correctly inserted into the electric outlet?	Insert the plug of the power cord correctly in the electric outlet.
	2 Is the connector of the power cord correctly inserted into the power inlet of the printer?	Insert the connector of the power cord correctly into the power inlet of the printer.
	3 Is the power cord damaged?	Replace the power cord. Consult with the dealer where the printer was purchased to make sure you obtain a cord made especially for the printer. Note: Do not use any power cord except one made especially for the printer.
	4 Is power supplied to the electric outlet the printer is connected to?	Check to make sure power is supplied to the outlet. If there are any problems, make sure power is supplied to the building. Or find out if a power failure has occurred.
	5 Is the main fuse in the building's fuse box burnt out?	If necessary, replace the main fuse in the building's fuse box, and reset the main breaker. Ask a qualified serviceman to carry out the replacement.



Refer to 2.2 Connection to Power

Symptom	Check	Corrective action
Paper is feeding, but nothing is printed.	1 Is the thermal printhead dirty? Is a label stuck to the head?	If it is dirty, remove the dirt with the attached head cleaner. If a label is stuck to the thermal printhead remove it. Note: Do not use a metal object to remove a label stuck to the inside of the printer. (This may damage the thermal printhead.) If adhesive label material is stuck to the thermal printhead, remove it with a soft cloth soaked in ethyl alcohol.
	2 Is the recommended ribbon or a ribbon of the same type used?	Use the recommended ribbon or a ribbon of the same type.



Refer to 4.6 Cleaning



Refer to 3.7 Setting the Ribbon

Symptom	Check	Corrective action
The printer is not printing neatly.	1 Are the media and the ribbon correctly set?	Correctly set the media and the ribbon.
	2 Is the printing density too high or too low?	Set the appropriate printing density using the menu or control software.
	3 Is the platen dirty? Is it deformed?	If it is dirty, clean it with ethyl alcohol. If it is deformed, replace it. Note: Consult with the dealer that supplied the printer concerning the replacement.
	4 Is the thermal printhead dirty? Is a label stuck to the head.	If it is dirty, remove the dirt with the attached head cleaner. If a label is stuck to the head, remove it. Note: Do not use a metal object to remove a label stuck to the inside of the printer. (This may damage the thermal printhead.) If adhesive label material is stuck to the print head, remove it with a soft cloth soaked in ethyl alcohol.
	5 Is the recommended ribbon or a ribbon of the same type used?	Use the recommended ribbon or a ribbon of the same type.
	6 Is the thermal printhead in the correct position for the media that is used?	Adjust the offset of the thermal printhead with the media thickness adjustment dial.
	7 Is the printer's head pressure balance correct for the width of the media that is used?	Adjust the thermal printhead pressure with the media width adjustment dial.



Refer to 3.6 Setting the Media



Refer to 3.7 Setting the Ribbon



Refer to Menu settings



Refer to 4.6 Cleaning



Refer to 4.2 Media Thickness Adjustment



Refer to 4.3 Media Width Adjustment

Symptom	Check	Corrective action
The printing position changes.	1 Are the media and the ribbon correctly set?	Correctly set the media and the ribbon.
	2 Is the platen dirty? Is it deformed?	If it is dirty, clean it with ethyl alcohol. If it is deformed, replace it. Note: Consult with the dealer that supplied the printer concerning the replacement.
	3 Are the data contents and the command signals from the host appropriate?	If an error message is displayed, check the content of the software and the communication status set by the host computer.
	4 Are the menu values set appropriately?	Set the correct menu values using the operating panel or the host computer.
	5 Are the sensitivities of the media sensors appropriate for the media that is used?	Set the media sensitivity to appropriate values. If this does not solve the problem, change the "Sensor level" that is set in the "System setup."



Refer to 3.6 Setting the Media



Refer to 3.7 Setting the Ribbon



Refer to 4.6 Cleaning



Refer to 3.3 LED Functions



Refer to Menu settings

Symptom	Check	Corrective action
The ribbon is wrinkled	1 Is the ribbon tension suitable for the ribbon that is used?	Adjust the tension with the adjust screw.
	2 Is the ribbon used correctly balanced to the right and left?	Adjust the left - right balance with the media width adjustment knob.
	3 Is the printing density too high?	Set the appropriate printing density using the menu or control software.
	4 Are the media and ribbon the recommended products or equivalent products?	Use the recommended products or equivalent products. If this does not correct the problem, contact a service representative.



Refer to 4.4 Adjusting the Ribbon

Symptom	Check	Corrective action
The ribbon slips (ribbon dirt is produced.)	1 Is the ribbon tension suitable for the ribbon that is used?	Adjust the tension with the adjust screw.



Refer to 4.4 Adjusting the Ribbon

Symptom	Check		Corrective action
The ribbon does not wind.	1	Is the ribbon set in the correct course?	Set the ribbon in the correct course.
	2	Is the ribbon winding direction reversed?	Set the correct winding direction.



Refer to 3.7 Setting the Ribbon

6. Appendixes

6.1 Specifications

Printing

Item	Description		
Printing method	Thermal transfer/Direct thermal		
Resolution	CL-S700 III/ CL-S700 III R	Main scanning line density	203 dot/inch (8 dot/mm)
		Sub- scanning line density	203 dot/inch (8 dot/mm)
		Head	864 dots (printable dots: 832 dots)
	CL-S703 III/ CL-S703 III R	Main scanning line density	300 dot/inch (11.8 dot/mm)
		Sub- scanning line density	300 dot/inch (11.8 dot/mm)
		Head	1275 dots (printable dots: 1240 dots)
Max. print width	CL-S700 III/ CL-S700 III R	104 mm / 4.1 inch	
		CL-S703 III/ CL-S703 III R	105 mm /4.1 inch
	CL-S700 III/ CL-S700 III R		2539.7 mm /99.99 inch
		CL-S703 III/ CL-S703 III R	1625.6 mm / 64.00 inch

Printing speed

Item	Description	
Printing speed setting	CL-S700 III	2 to 12 inches per second
	CL-S703 III/CL-S700 III R/CL-S703 III R	2 to 10 inches per second
	CL-S700 III/CL-S703 III	2 to 7 inches per second (With optional peeler)
	CL-S700 III R/CL-S703 III R	2 to 7 inches per second (With optional peeler)

Print mode

Item	Description
Batch mode	Normal printing (single or multiple sheets)
Tear off mode	Feeds back media to the tear-off position after printing is completed.

Item	Description
Cut mode *1	Prints while cutting at designated sheet units. The following two kinds of cut mode operations are done. <ul style="list-style-type: none"> • Backfeed • Cut through (Cut through refers to stopping part-way through printing the 'next label' to make the cut. After cutting, printing restarts but there is a chance of a small gap or mark at the temporary stop position.)
Peel mode *1	Peels labels from the liners after printing them.

*1 Options can be separately purchased.

Media

Item	Description	
Types of media	Roll, fanfold (Continuous media, die-cuts, continuous tags, paper or tickets) When the print speed is set to 11-12 IPS at CL-S700III, the inner roll paper cannot be used.	
Recommended media	Thermal transfer: Label media (LINTEC Corporation LR1111) Direct thermal media: Label media (Ricoh 150LA-1), tag media (Ricoh 130LHB)	
Max. media width	118.0 mm / 4.65 inch	
Min. media width	25.4 mm / 1.00 inch	
Min. label width	7.62 mm / 0.30 inch	
Min. label pitch	6.35 mm / 0.25 inch	
*1		
Max. media thickness	0.254 mm / 0.01 inch	
Max. media length	CL-S700 III/CL-S700 III R	2539.7 mm / 99.99 inch
	CL-S703 III/CL-S703 III R	1625.6 mm / 64.00 inch
Min. media length	6.35 mm / 0.25 inch	
Min. media thickness	0.0635 mm / 0.0025 inch	
On-board roll media diameter	Max. outside diameter: 203 mm / 8 inch Media core: 38~76 mm / 1.5~3 inch	
Rewinding roll media diameter (CL-S700 III R/CL-S703 III R only)	Media core: 26, 40, 45 mm / 1.02, 1.57, 1.77 inch	

*1 When a media pitch of less than 1 inch is used, activate the "Small Media Adjustment" setting in the "Page Setup."

Ribbon

Item	Description
Recommended ribbon	B110A Ricoh
Max. ribbon width	114.0 mm / 4.50 inch
Min. ribbon width	25.4 mm / 1.00 inch
Max. ribbon length	450.0 m / 1476 feet
Max. roll diameter	86.5 mm / 3.40 inch
Inner diameter of the paper core	25.4 ±0.254 mm / 1.00 ±0.01 inch
Ribbon end tape length	80 mm / 3.15 inch
Ribbon end detection	Ribbon out is detected by the ribbon sensor

Bar code

Item		Description
Datamax® emulation	One-di- mension	<ul style="list-style-type: none"> •Code3of9 / •UPC-A / •UPC-E / •EAN-13 (JAN-13) / •EAN-8 (JAN-8) / •Interleaved2of5 / •CODE128 / •HIBC (Modulus 43-used code 3 of 9) / •CODABAR (NW-7) / •Int2of5 (Modulus10-used Interleaved 2 of 5) / •Plessey / •CASE CODE •UPC2DIG ADD / •UPC5DIG ADD / •Code93 / •Telepen / •ITF14 / •ITF16 / •Matrix2of5 / •COOP2of5
	Two-di- mension	<ul style="list-style-type: none"> •MaxiCode / •PDF-417 / •Data Matrix / •QR Code / •Aztec / •GSI Databar Omnidirectional (RSS-14) / •GSI Databar Truncated (RSS-14 Truncated) / •GSI Databar Stacked (RSS-14 Stacked) / •GSI Databar Stacked Omnidirectional (RSS-14 Stacked Omnidirectional) / •GSI Databar Limited (RSS Limited) / •GSI Databar Expanded (RSS Expanded)
Zebra® emulation	One-di- mension	<ul style="list-style-type: none"> •Code11 / •Interleaved2of5 / •Code39 / •EAN-8 / •UPC-E / •Code93 / •Code128 / •EAN-13 / •Industrial2of5 / •Standard2of5 / •ANSI CODABAR / •LOGMARS / •MSI / •Plessey / •UPC/EAN Extensions / •UPC-A / •POSTNET / •Planet
	Two-di- mension	<ul style="list-style-type: none"> •Code49 / •PDF-417 / •CODABLOCK / •MaxiCode / •Micro PDF-417 / •Data Matrix / •QR Code / •TLC39 / •Aztec / •GSI Databar Omnidirectional (RSS-14) / •GSI Databar Truncated (RSS-14 Truncated) / •GSI Databar Stacked (RSS-14 Stacked) / •GSI Databar Stacked Omnidirectional (RSS-14 Stacked Omnidirectional) / •GSI Databar Limited (RSS Limited) / •GSI Databar Expanded (RSS Expanded)
Eltron® emulation	One-di- mension	<ul style="list-style-type: none"> •Code39 / •Code93 / •Code128 / •Codabar / •EAN-8 / •EAN-13 / •German Postal Code / •Interleaved2of5 / •POSTNET / •Planet / •Japanese Postnet / •UCC/EAN-128 / •UPC-A / •UPC-E / •UPC-Interleaved2of5 / •Plessey (MSI-1) / •MSI-3
	Two-di- mension	<ul style="list-style-type: none"> •Aztec / •Data Matrix / •MaxiCode / •PDF-417 / •QR Code / •GSI Databar Omnidirectional (RSS-14) / •GSI Databar Limited (RSS Limited) / •GSI Databar Stacked (RSS-14 Stacked) / •GSI Databar Truncated (RSS-14 Truncated)

Font

Item	Description
Datamax® emulation	1. Seven kinds of fixed pitch font <ul style="list-style-type: none"> • Overseas, English fonts and European fonts 2. OCR fonts OCR-A, OCR-B*1 3. Proportional fonts CG Triumvirate smooth font CG Triumvirate bold smooth font CS Sans CJK 203 dpi: 6, 8, 10, 12, 14, 18, 24, 30, 36, 48 points 300 dpi: 4, 5, 6, 8, 10, 12, 14, 18, 24, 30, 36, 48 points Character set: Conforms with code page 850 standards 4. TrueType™ rasterizer*2
Zebra® emulation	1. Five kinds of fixed pitch font <ul style="list-style-type: none"> • Overseas, English fonts and European fonts 2. OCR fonts OCR-A, OCR-B*1 3. Proportional fonts CG Triumvirate Condensed Bold CS Sans CJK 4. TrueType™ rasterizer*2
Eltron® emulation	1. Five kinds of fixed pitch font <ul style="list-style-type: none"> • Overseas, English fonts and European fonts 2. Two kinds of fixed pitch font <ul style="list-style-type: none"> • Numbers only

*1 Depending on the reader, OCR font recognition may be poor.

*2 UFST™ and TrueType™ rasterizer are licensed from Monotype Imaging, Inc.

Symbol set*2

Item	Description
Single-Byte sets (Datamax® / Zebra® emulation)	<ul style="list-style-type: none"> •PC866U Ukraina*1 / •PC Cyrillic / •ISO 60 Danish/Norwegian / •Desk Top / •ISO 8859/1 Latin 1 / •ISO 8859/2 Latin 2 / •ISO 8859/9 Latin 5 / •ISO 8859/10 Latin 6 / •ISO 8859/7 Latin/Greek / •ISO 8859/15 Latin 9 / •ISO 8859/5 Latin/Cyrillic / •ISO 69:French / •ISO 21:German / •ISO 15:Italian / •Legal, Math-8 / •Macintosh / •Math / •PC-858 Multilingual / •Microsoft Publishing / •PC-8 / •Code Page 437 / •PC-8 D/N / •Code Page 437N / •PC-852 Latin 2 / •PC-851 Latin/Greek / •PC-862 Latin/Hebrew / •Pi Font / •PC-850 Multilingual / •PC-864 Latin/Arabic / •PC-8 TK / •Code Page 437T / •PC-1004 / •PC-775 Baltic / •Non-UGL / •Generic Pi Font / •Roman-8 / •Roman-9 / •ISO 17:Spanish / •ISO 11:Swedish / •Symbol / •PS Text / •ISO 4:United Kingdom / •ISO 6:ASCII / •Ventura International / •Ventura Math / •Ventura US / •Windows 3.1 Latin 1 / •Wingdings / •Windows 3.1 Latin 2 / •Windows 3.1 Baltic (Latv, Lith) / •Windows 3.0 Latin 1 / •Windows Latin/Cyrillic / •Windows 3.1 Latin 5
Double-byte sets (Datamax® emulation)	<ul style="list-style-type: none"> •EUC / •JIS / •Shift JIS / •Unicode / •KS Code / •GB Code / •UTF-8

*1 "PC866U Ukrainian" is supported only in Datamax® emulation.

*2 Use it when drawing a TrueType font. Eltron® emulation does not support a TrueType font.

Control language

Description
Supports the Datamax® language, Zebra® language and Eltron® language

Outline of electronic devices

Item	Description
CPU	32-bit RISC CPU
ROM	Standard equipment: FLASH ROM 256 MBytes (User area: 24 MBytes)
RAM	Standard equipment: DDR SDRAM 256 MBytes (User area: 4 MBytes)

Media detection sensors

Item	Description
Transparent sensor	Detects media gap between labels, notches on tags, and media out
Reflective sensor	Detects reflective mark on back of media and media out
Label peeling sensor *1	

*1 Options can be separately purchased.

Communication interfaces

Item	Description
USB	USB2.0 Compatible (High-speed 480 Mbps)
LAN	Wired LAN (100BASE-TX / 10BASE-T)

Communication interface options

Item	Description	
Serial	2400 4800 9600 19200 38400 57600 115200 bps	
Parallel	IEEE1284 (Compatible / Nibble / ECP Mode)	
Wired LAN	IFI-EFX1	Ethernet (100BASE-TX / 10BASE-T)
	IFI-EFX3	
	IFI-EFX2	Ethernet (100BASE-TX/10BASE-T) + USB 2.0 high-speed compatible x 2
Wired LAN / Wireless LAN	IFI-ES04	Ethernet (10BASE-T/100BASE-TX/1000BASE-T) + IEEE 802.11 b/g/n:2.4 GHz, IEEE 802.11 a/n/ac:5 GHz
	IFI-WFX4	IEEE802.11n, IEEE802.11a, IEEE802.11g, IEEE802.11b + Ethernet (10BASE-T/100BASE-TX/1000BASE-T) + USB 2.0 high-speed compatible

Indications and switches

Item	Description
LCD	240 x 320 dots TFT graphic LCD (resistive touch panel)
LED	POWER, ERROR
Buzzer	Alarms, errors, etc.
Operating panel keys	PAUSE, FEED
Head-up detection sensor	Detects head open
Rewinder cover detection sensor (CL-S700 III R)	Detects rewinder cover open
Power switch	Turns power on and off

Power

100–240 V (–10%+6%), 3.5–1.5 A, 50/60 Hz

Applicable standards

UL, cUL, FCC, IC, CE, UKCA *

* Please contact us for information on other regions and the latest status such as standard numbers.

Environment

Operating temperature conditions: Operating temp. 0 to 40°C (32 to 104°F), humidity 30 to 80%, condensation free

(Conditions: ventilation, and natural convection)

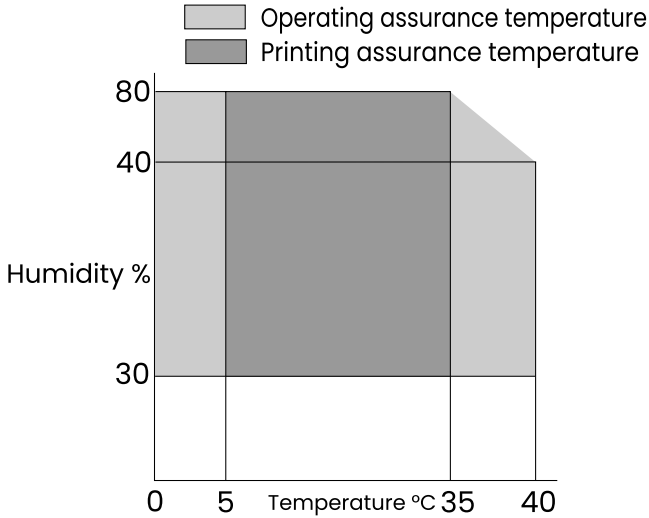

Storage temperature conditions: Temp. -20 to 60°C (-4 to 140°F), humidity 5 to 85%

Note:

- Conditions: ventilation, and natural convection
- Stored with head up
- No condensation

* However, for storage at high temperature and humid environments, the combination of 40°C (104°F) and 85% RH (no condensation) is taken as the worst value.

External dimensions

* Dimensions are design values. Actual dimensions may vary due to variance in manufacturing processes.

Approx. 255 (W) × 490 (D) × 265 (H) mm / 10 (W) × 19.3 (D) × 10.4 (H) inch
(CL-S700 III/CL-S703 III)

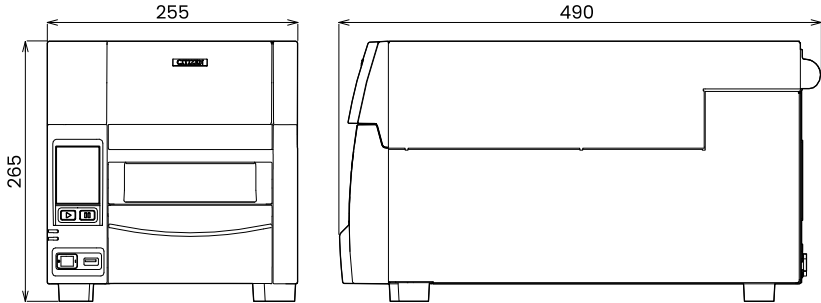

Approx. 255 (W) × 489 (D) × 385 (H) mm / 10 (W) × 19.3 (D) × 15.2 (H) inch
(CL-S700 III R/CL-S703 III R)

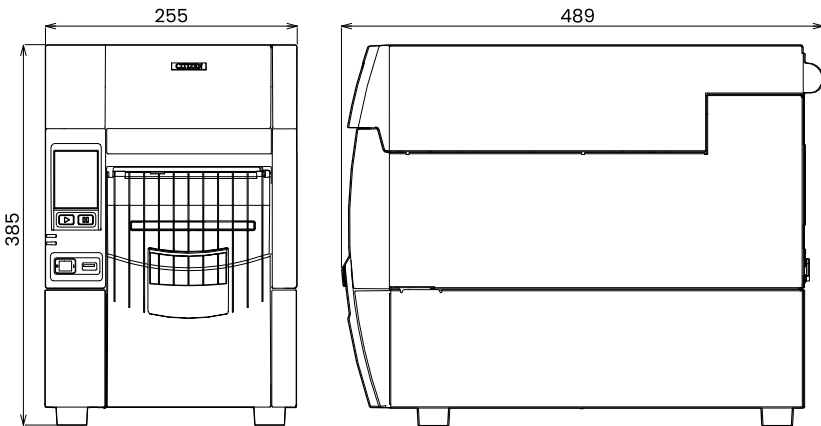

Weight

Approx. 13.5 kg (CL-S700 III/CL-S703 III)

Approx. 18.5 kg (CL-S700 III R/CL-S703 III R)

Option

- Auto-cutter unit

- Peeler unit
- Serial interface board
- Parallel interface board
- Wired LAN interface board
- Wireless LAN interface board
- Rewinder kit

6.2 Interfaces

This printer is connected to a computer and prints according to commands sent from the computer.

There are two methods of connection to the computer that can be used to connect to a compatible device. In addition, as options, the computer can be connected by serial, parallel, wired LAN, and wireless LAN connections.

USB Interface

Specifications

Standards	Complies with Universal Serial Bus Specification 2.0
Transmission speed	480 Mbps (High-Speed) / 12 Mbps (Full-Speed)
Receive buffer	16 kB
Connector	USB Type B

Signal line and pin arrangement

Pin No.	Signal code	Signal	Function
1	VBUS	USB power	USB power (+5 V)
2	D -	Signal line -	- signal line
3	D +	Signal line +	+ signal line
4	GND	GND	GND

Wired LAN interface

Support protocol

Network layer	ARP, IP, TCP
Transport layer	TCP, UDP
Application layer	DHCP, HTTP, SNMP, Raw Socket Port

Raw Socket Port

Perform two-way communication of print data and printer status.

Port No.	9100 (user-configurable)
Port communication direction	Two-way
Socket max. connections	8
Printable connections	1 (other sockets are reserved)
Timeout	Default value: 60 sec Can be set between 0 and 300. No timeout when "0" is set.

HTTP Server

Settings of printer unit and network are done by LinkServer Web Interface.

For details, see “LinkServer Web Interface Configuration”.



Refer to Configuring Printer Settings Using LinkServer

Port No.	80
Max. simultaneous connections	4
HTTP version	HTTP/1.1

DHCP

IP address is automatically obtained from DHCP server within 60 seconds after power is connected.

If the address cannot be obtained automatically, fixed IP address (default value: 169.254.1.10) is applied.

SNMP Agent

By using the SNMP agent function, responses are provided to requests from the SNMP manager.

SNMP Version	SNMPv2 (Trap function is not supported)
Port No.	161
Supported MIB	HOST-RESOURCES-MIB, Citizen-MIB (Private)
Community name	public

Connector Connections

- Compatible connectors
Printer: RJ-45 connector



Caution

- Please do not insert the USB cable by mistake. Doing so may damage the cable and connector.
- With the wired LAN interface that is provided as standard, data in XML format cannot be printed.

Pin No.	Signal name	Function
1	TX+	Send (+)
2	TX-	Send (-)
3	RX+	Receive (+)
4	N.C	-
5	N.C	-
6	RX-	Receive (-)
7	N.C	-
8	N.C	-

Function of LED

The indications by LED are given below.

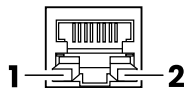

1: Network communication speed display

Communication speed	LED (green)
100 Mbps	ON
10 Mbps/disconnected	Blink

2: Network status display

Display description	LED (yellow)
Connected	ON
Disconnected	OFF
Communicating data	Blink

Configuring Printer Settings Using LinkServer

Printer and network settings can be configured using a Web browser or Android app via the printer's built-in LinkServer function.

Notes

For Android, you need to download the app and provide a USB cable yourself.

The Android app can be downloaded from Google Play.

<https://play.google.com/store/apps/details?id=com.citizen.app.linkserver>

LinkServer user roles

LinkServer has the following three user roles available: User, Operator, and Administrator.

The menus that appear for each user role can be changed to restrict operational access to LinkServer.

The Home screen for the user role appears when first connecting.

LinkServer menu configuration

The following figure illustrates the LinkServer menu configuration.

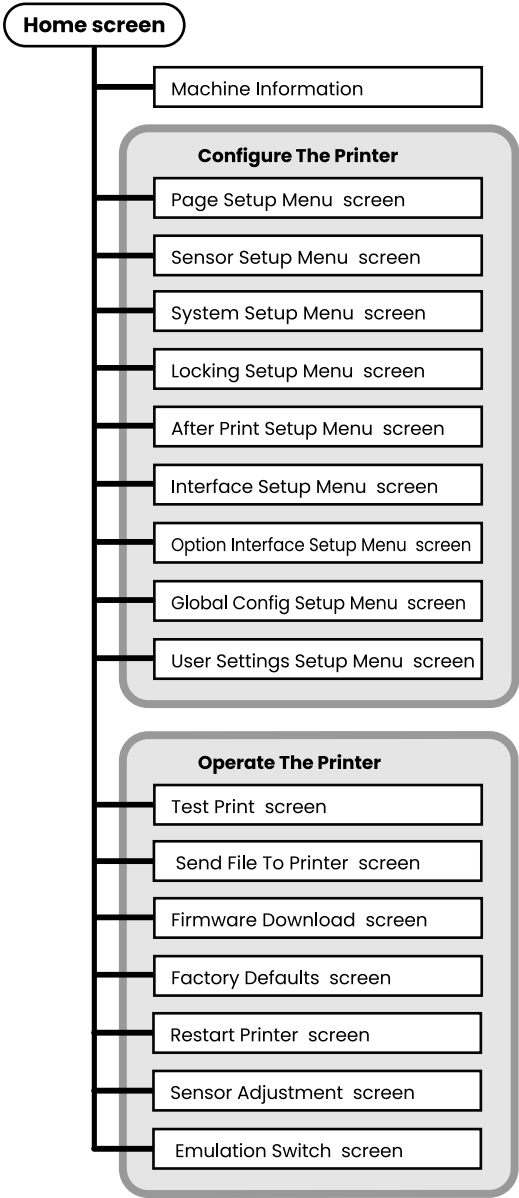

LinkServer connection procedure

Wired LAN

1. Open a Web browser and enter the IP address of the desired printer into the address bar (area circled in red).

The example illustrates the entry of "http://192.168.0.3".



2. Press the [LOG IN] button to display the authentication screen.

In the factory default state, the authentication password setting screen is displayed.

Link Server™

Set Password Configuration

User Level	User	Operator	Administrator	
Username	Not logged in	<input type="text" value="Operator"/>	<input type="text" value="Admin"/>	<input type="button" value="SAVE"/> Save settings and return to main menu
Password	Not needed	<input type="text"/>	<input type="text"/>	<input type="button" value="CANCEL"/> Cancel any changes
				<input type="button" value="BACK"/> Back to main menu

Copyright © Citizen Systems Japan Co., Ltd. 2014

There are three types of user privileges for the Web Monitor: User, Operator, and Administrator. Press the [SAVE] button after entering the user names and passwords for the Operator and Administrator privileges to save the authentication information to the printer. Thereafter, if you press the [LOG IN] button, the authentication screen will be displayed. Enter the set authentication information.

Notes

- Be sure to specify 1 to 20 single-byte alphanumeric characters and symbols.
- You cannot specify "Operator" in the user name and password for the Operator privilege.
- You cannot specify "Admin" in the user name and password for the Administrator privilege.

3. The Home screen is displayed.

After successful authentication, the Home screen for the Operator or Administrator privilege appears.

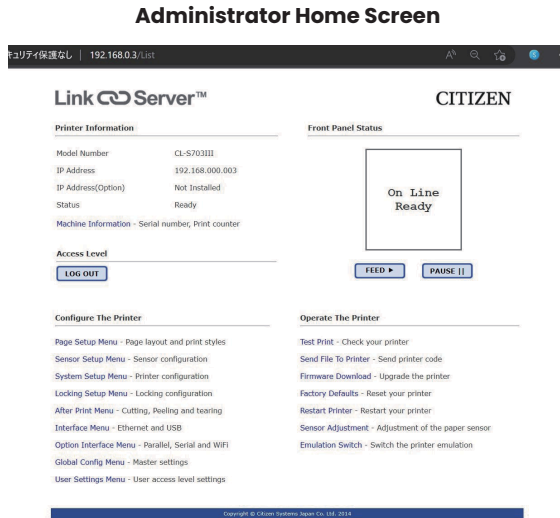

The menus that appear for the User and Operator roles can be changed from the User Settings menu.

Notes

If you forget the set user name and password, initialize the settings by operating the printe unit to return to the factory default state, and set the authentication information again.

Note that when you initialize the settings, not only the network settings but all the settings of the printer are initialized. We recommend backing up the printer settings in advance. You can import or export the printer settings from the LabelPrinterUtility. For details, refer to the manual of the LabelPrinterUtility.

4. Press the Menu button on the Home screen to perform printer operations.

- Printer Information: Displays printer information.
- Configure The Printer: Provides access to the same settings as configured with LabelPrinterUtility.
- Operate The Printer: Used to operate the printer.

5. Once you are finished, press the [LOG OUT] button to log out.

The Home screen for the User role appears again after logging out.

USB (Android device)

1. Preparation

You will need a so-called USB OTG (On-The-Go) adapter.

Which has a micro USB or Type-C male connector on the Android side (depending on your Android device) and a Type-A female connector on the other side. Then you can connect a regular USB cable for printer which has a Type-A male and Type-B male to connect to a printer.

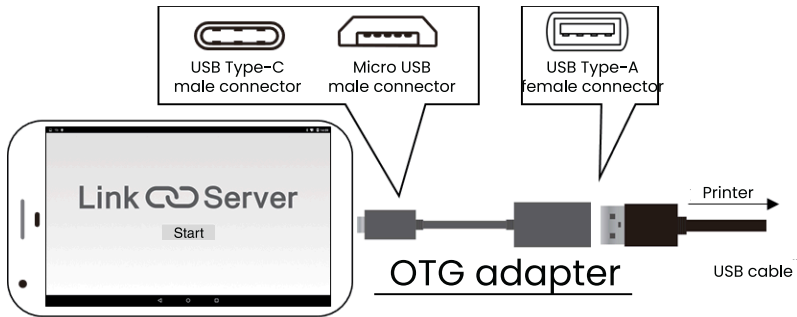

2. Usage

The LinkServer app automatically starts up when a supported printer model is connected by USB to your Android device.



The app shows you the printer information or lets you set up the printer.

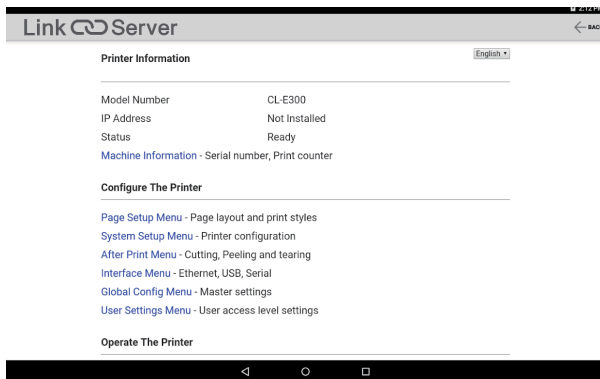

Press "SAVE" to apply changes.

The printer will automatically restart and save the new settings.

Wait until the printer starts up completely if you wish for further operations.

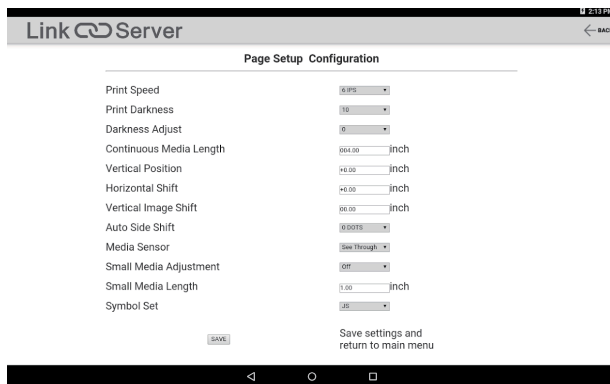

Serial Interface (Option)

Specifications

Transfer system	Start/stop asynchronous duplex communication
Signal level	RS-232C
Baud rate	2400, 4800, 9600, 19200, 38400, 57600, 115200 bps
Bit length	7-bit, 8-bit
Stop bit	1-bit, 2-bit
Parity	Odd, even, none
Connector	D-SUB 25PIN

Signal line and pin arrangement

Pin No.	Signal code	Signal name	Function
1	FG	Protective grounding	Protective grounding
2	TXD	Transmitted data	Signal line that transmits data from the printer to other devices
3	RXD	Received data	Signal line that transmits data from other devices to the printer
4	RTS	Transmission request	Signal line that becomes active when the printer can receive data
5	CTS	Able to transfer data	Signal line that becomes active when other devices can receive data from the printer
6	DSR	Data set relay	Signal line used by external devices to notify printer that they are ready to communicate
7	SGND	Signal line ground	Shows the ground level of the signal line
8-13	NC	-	Not used
14	VCC	+3.3 V	(FACTORY USE ONLY)
15-19	NC	-	Not used
20	DTR	Data terminal relay	Signal line used by printer to notify external devices that printer is ready to communicate
21-25	NC	-	Not used

Dip switch

Communication conditions settings can be changed by using the dip switch available on the interface board.

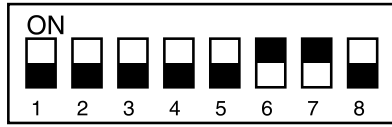

DIP switch

Respective functions of the switches are as follows.

Switch No.	Function	ON	OFF (Factory setting)
1	Selection of communication conditions setting	According to setting of dip switch	According to setting in printer unit
2	Handshake	XON / XOFF	DTR / DSR
3	Bit length	7-bit	8-bit
4	Parity check	Yes	No
5	Parity selection	Even	Odd
6	Selection of baud rate	See below	
7			
8	Reservation	-	-

Baud rate selection

Switch No.		Baud rate (bps)
6	7	
OFF	OFF	2400
ON	OFF	4800
OFF	ON	9600
ON	ON	19200 (factory setting)

XON/XOFF Protocol

a. Requirements to output X-ON code

- Communication is possible when the power is on.
- When the receive buffer has less than 128 bytes available, XOFF code is output, then the receive buffer has at least 1024 bytes available.

b. Requirements to output the X-OFF code

- When the receive buffer has less than 128 bytes available

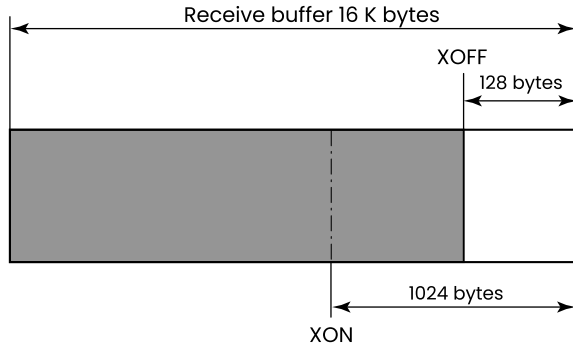

DTR Protocol

a. Conditions when the DTR signal is “Ready (High)”

All the following conditions are satisfied.

- The receive buffer is 128 bytes or more available capacity.
 - * When the receive buffer has less than 128 bytes available and the DTR signal has changed to BUSY (Low) status, BUSY status is maintained until the capacity of the receive buffer has reached 1024 bytes or more.

b. Conditions when DTR signal is “Busy (Low)”

- When the receive buffer has fallen to less than 128 bytes available.

Parallel Interface (Option)

Specifications

Transfer system	8-bit parallel data
Receive buffer size	16 kB
Transmission modes	<p>Compatible mode: It is an asynchronous forward direction of the byte width (from host to printer) channel, and the interface line of the data is operated in accordance with signal line definitions of Centronics.</p> <p>NIBBLE mode: Nibble mode is asynchronous reverse channel communication with data transmission controlled by the host computer. In reverse channel transmission, the data is nibble transmitted in two parts using four status lines (Fault, Select, PE, and Busy). And nibble mode can be used along with compatible mode to send data in two directions.</p> <p>ECP mode: ECP mode permits bi-directional asynchronous data transmission, and thanks to its interlock handshake, it does not require the timing necessary with compatible mode.</p>

Signal level	IEEE1284 standard
--------------	-------------------

Signal line and pin assignment table

Pin No.	Signal name	I/O	Function
1	*STROBE	Input	Strobe signal to read in 8-bit data
2-9	DATA1-8	Input	8-bit parallel signal
10	*ACKNLG	Output	8-bit data request signal
11	BUSY	Output	Signal specifying printer busy
12	PERROR	Output	Signal specifying media out
13	SELECT	Output	Signal specifying if the printer is on-line (printing enabled) or off-line (pausing)
14	AUTOFD	Input	Invalid (ignored)
15	NC	-	Not used
16	GND	-	Signal ground
17	FGND	-	Frame ground
18	P.L.H	Output	Peripheral logic high (pull up to +5 V at 1.2 k Ω)
19-30	GND	-	Ground for twisted pair return
31	*INIT	Input	Printer reset
32	*FAULT	Output	Signal specifying printer error
33-35	NC	-	Not used
36	SELECTIN	Input	Invalid (ignored)

Parallel port status signals when an error occurs

The status of a signal line will not be changed in bi-directional mode such as nibble or ECP mode.

Error	Change in the status of a signal line in compatible mode
Paper end	Busy : L \rightarrow H PError : L \rightarrow H Select : H \rightarrow L nFault : H \rightarrow L
Error other than paper end ● Head open ● Other	Busy : L \rightarrow H PError : L \rightarrow unchanged Select : H \rightarrow L nFault : H \rightarrow L
Conditions for Busy	● Receive buffer full ● Data being read ● Error

Compatible timing specification

[When power is on] (Time it goes off-line)

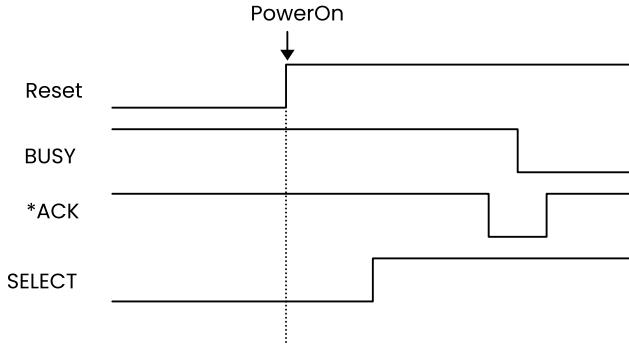

[While receiving data]

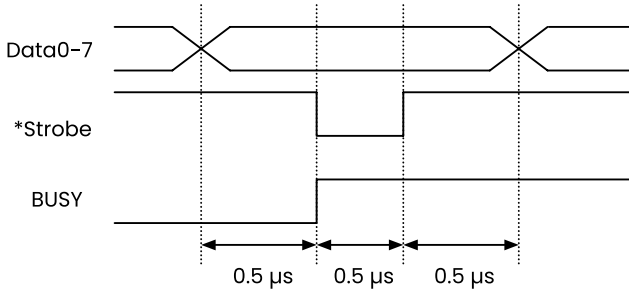

* Busy rises when *Strobe signal starts, and data is latched with *Strobe signal starts.

[While receiving INIT signal]

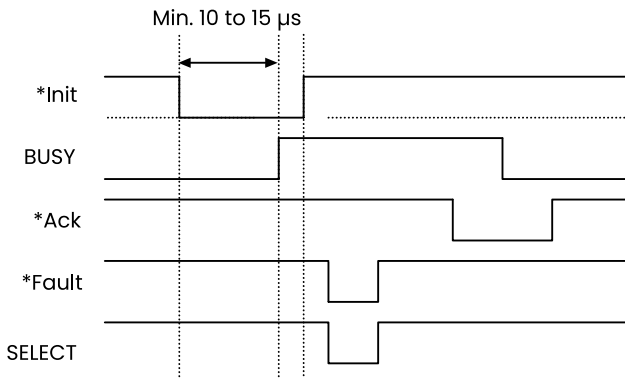

* If the *Init signal does not have width of 10 to 15 μ sec or more, it cannot act as an Init signal. If it is lower, the *Init signal is ignored. BUSY starts up when the *Init signal is perceived.

Relation of the timing of the BUSY signal and the *ACK signal

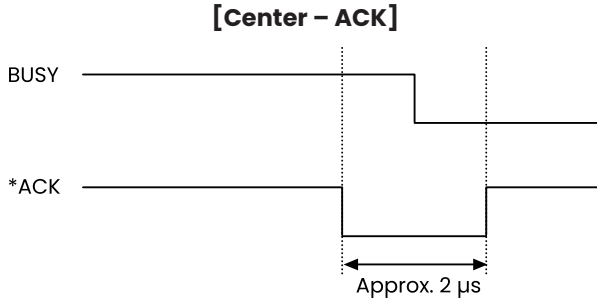

Middle-range optional wired LAN/wireless LAN interface (IF1-EFXx, IF1-WFXx)

Middle-range optional wired LAN/wireless LAN interface compatible with XML web applications.

For details on this board, refer to a separate manual.

High-end optional wired LAN/wireless LAN interface (IF1-ESxx)

High-end optional wired LAN/wireless LAN interface compatible with various protocols.

For details on this board, refer to a separate manual.

Replacing the Interface Board



Always turn off the power to the printer before replacing the interface board. Do not pull it out with unnecessary force. This will cause an accident.

Replacement Method

1. Remove the screws (2 nos) that the fixing the interface cover.

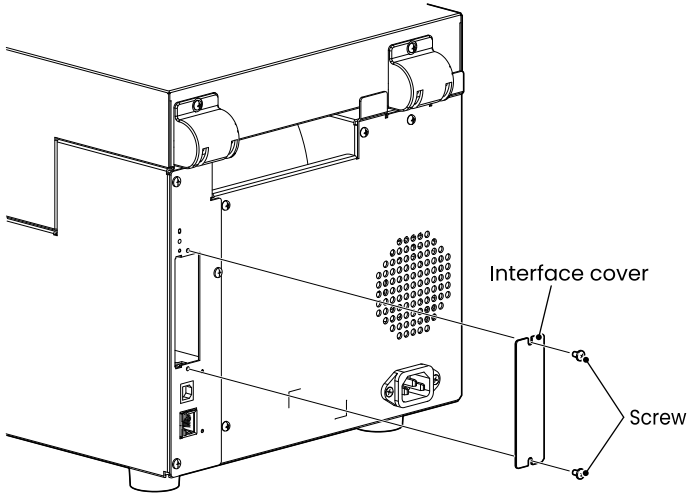

2. Insert the interface port into the slot, and connect to the interface connector inside the printer.

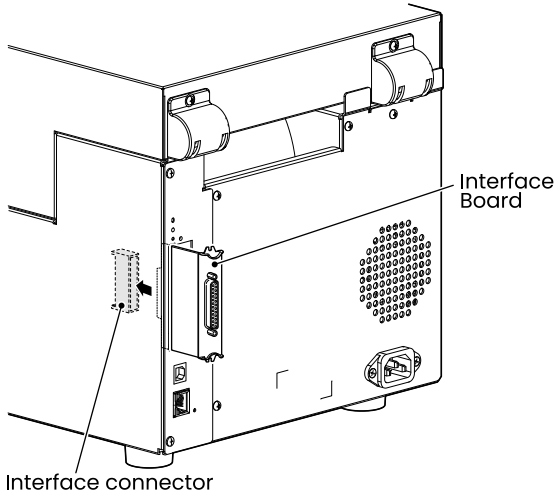

3. Fix the interface port to the printer by using the removed screw (2 nos).

